

March 2021

Thermal Management of Lithium-ion Batteries Using Supercapacitors

Sanskruta Dhotre
University of South Florida

Follow this and additional works at: <https://digitalcommons.usf.edu/etd>



Part of the [Electrical and Computer Engineering Commons](#)

Scholar Commons Citation

Dhotre, Sanskruta, "Thermal Management of Lithium-ion Batteries Using Supercapacitors" (2021). *USF Tampa Graduate Theses and Dissertations*.
<https://digitalcommons.usf.edu/etd/8759>

This Thesis is brought to you for free and open access by the USF Graduate Theses and Dissertations at Digital Commons @ University of South Florida. It has been accepted for inclusion in USF Tampa Graduate Theses and Dissertations by an authorized administrator of Digital Commons @ University of South Florida. For more information, please contact digitalcommons@usf.edu.

Thermal Management of Lithium-ion Batteries
Using Supercapacitors

by

Sanskruta Dhotre

A thesis submitted in partial fulfillment
of the requirements for the degree of
Master of Science in Electrical Engineering
Department of Electrical Engineering
College of Engineering
University of South Florida

Major Professor: Arash Takshi, Ph.D.
Ismail Uysal, Ph.D.
Wilfrido Moreno, Ph.D.

Date of Approval:
March 10, 2021

Keywords: Thermal Runaway, Hybrid Battery-Supercapacitor Architecture, Battery
Management Systems, Internal heat Generation

Copyright © 2021, Sanskruta Dhotre

Dedication

I wish to dedicate this thesis to my late grandfather, Gurunath Dhotre, who has always inspired me to be the best version of myself, my parents, without whose continuous love and support my academic journey would not have been the same and my brother for encouraging me to soldier on forward no matter what the obstacle.

Acknowledgments

First and foremost, I would like to express my gratitude to my guide Dr. Arash Takshi of the Electrical Department, whose unwavering support and guidance made this academic study possible. His continuous understanding, patience and valuable suggestions have helped me immensely throughout the duration of this thesis. I would also like to thank Dr. Manoj Ram Kumar of PolyMaterials App for presenting with and leading me to undertake this exciting opportunity.

Table of Contents

List of Tables.....	ii
List of Figures	iii
Abstract	iv
Chapter 1: Introduction	1
1.1 Motivation and Background	1
1.2 Thesis Objective.....	3
1.3 Market Survey.....	5
1.4 Literature Survey	5
Chapter 2: Dynamic charging/discharging of the battery-supercapacitor for thermal Management	11
2.1 Brief Overview of EV Batteries	11
2.2 Basic Framework and Hypothesis	19
2.3 Hypothesis Review	22
2.4 Hypothesis Results.....	23
Chapter 3: Thermal Behavior of Li-ion Batteries	25
3.1 Experimental Setup.....	25
3.2 Results and Discussions.....	27
3.2.1 Constant Current Discharge of the Battery	27
3.2.2 Simulation of the Effects of the Supercapacitor	30
Chapter 4: Conclusion and Future Works.....	34
4.1 Conclusions.....	34
4.2 Future Works	35
References	38
Appendix A: Copyright Permission	41
Appendix B: Mathematical Model of the Hypothesis.....	42

List of Tables

Table 2.1 Various car models and their respective battery specifications	11
Table 2.2 Input parameters for the hypothesis model.....	22
Table 2.3 Time taken for the total discharge at different settings of the electronic load.....	23
Table 3.1 Components used for the test setup	25
Table 3.2 Mean slopes at different intervals for the graphs 3.5(a) and 3.5(b).....	32

List of Figures

Figure 1.1 Global electric car stock from 2010-2019. (BEV- Battery Electric Vehicles; PHEV – Plug-in Hybrid Electric Vehicle	2
Figure 1.2 Amount of Cobalt and Lithium used for the construction of batteries	5
Figure 2.1 Electric vehicle battery module arrangement on the chassis	15
Figure 2.2 Schematic diagram of the test circuit	18
Figure 2.3 Datasheet of the Panasonic NCR18650B	19
Figure 2.4 Temperature curve of the battery for (a) constant current discharge of 1.6A and reduction of 0.2A during supercapacitor participation (b) constant current discharge of 2.4A and reduction of 0.4A during supercapacitor participation	24
Figure 3.1 Circuit diagram of the test setup	26
Figure 3.2 Placement of the temperature sensor on the battery body	27
Figure 3.3 Temperature curves for the constant discharge current setting (a)1.6A (b)1.75A (c)2.0A (d)2.2A (e)2.4A	28
Figure 3.4 Comparison graphs of Device 0 at different constant current discharge values.....	29
Figure 3.5 (a)Simulation of the battery upon supercapacitor integration (b)Battery temperature at constant current discharge at 2.2A.....	31
Figure 3.6 Voltage of the battery during supercapacitor simulation.....	32
Figure 3.7 Zoomed images of the slope of graphs 3.5(a) and 3.5(b).....	33

Abstract

As the market for renewable resources increases, the bandwidth of applications using Li-ion batteries as the primary source of energy also increases. Li-ion batteries are at a risk of undergoing thermal runaway under uncontrolled situations. Overcharging, over-discharging, high internal temperatures, etc. are all factors towards the gradual degradation of Li-ion battery performance. Therefore, it is important to have an efficient battery management system to ensure the smooth functioning of the battery.

Thermal management systems is an important aspect of the battery management system to keep battery temperatures under critical levels. Although, there are various methods of cooling down the battery such as air or liquid cooling, these methods are remedial in nature and not precautionary. Plenty of research is being done in order to remove heat from the primary source itself. This thesis explores the feasibility of a novel approach of using a hybrid battery-supercapacitor architecture as a means of thermal management.

Chapter 1: Introduction

1.1 Motivation and Background

As the reserves of fossil fuels and other perishable energy sources are reducing, the demand for renewable energy is seeing a steady rise. The energy industry now inclines towards electric alternatives of limited resources. Photovoltaic cells (solar cells) have a great source for off-grid power generation which have become a standard for newly constructed buildings, recreational vehicles (RVs), water heaters and many other applications. Not only have they evolved drastically and proven to be a reliable source to clean energy but also the manufacturing cost of solar cells has reduced by a considerable margin over the years, making it more affordable to the masses. Incandescent lightbulbs have slowly replaced by LED lights, but one can hardly disagree when one says that the Li-ion batteries have been a game changer in the renewable energy sector. Li-ion batteries are extensively used in Hybrid Electric Vehicles (HEVs), Electric vehicles (EVs), etc. due to its high power to weight ratio. Unlike traditional fuel cars, EVs have no harmful byproducts like carbon monoxide, carbon dioxide, nitrous oxide, etc. Electric Vehicles accounted for 2.6% of global car sales and saw a 40% increase in sales in 2019 than the previous year [8]. The share of EVs in the market is only going to increase in the coming years. Figure1.1 shows increase in Electric Vehicle stock from 2010-2019.

Lithium-ion (Li-ion) batteries are a type of rechargeable batteries which play an extremely important role in the field of renewable energy. The high energy density, low self-discharge and high lifecycle make it an attractive energy storage device. Li-ion battery structure consists of an

anode, a cathode, and a conducting electrolyte. In most commercial Li-ion batteries, graphite is used as anode, the cathode comprises of a metal oxide typically lithium cobalt oxide (LiCoO₂) and the electrolyte is lithium salt [18]. Since lithium is a highly reactive material it is important to guarantee its efficient handling. Research related to Li-ion batteries are generally concerning improving safety, reducing production costs, extending battery life, increasing the energy density, etc.

Global electric car stock, 2010-19

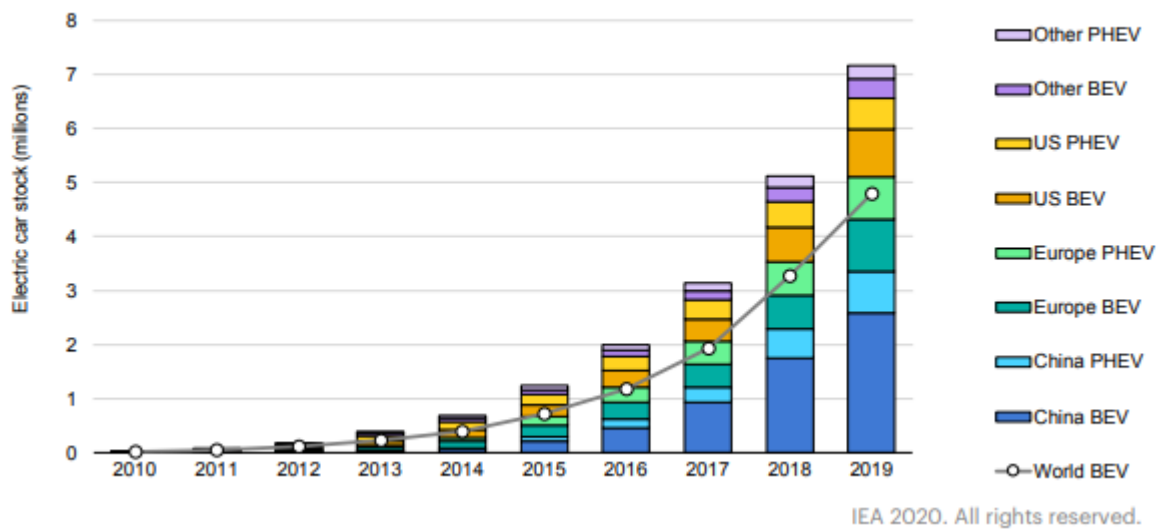

Figure 1.1: Global electric car stock from 2010-2019 (BEV - Battery Electric Vehicle; PHEV - Plug-in Hybrid Electric Vehicle (Based on the report Global EV Outlook 2020 [8])

Due to the flammable materials used in the construction of the Li-ion battery, it is extremely important to ensure that the battery does not reach hazardous temperatures during operation. Electric Vehicle applications are robust environments which required a great deal of thermal management techniques to be employed. Poor thermal management of batteries can affect the life cycle, charging and discharging capacity, cell balancing capabilities of the battery. Extreme increase in internal battery and the failure of the responsible battery thermal management system

have led to batteries exploding in a number of cases. Therefore, the main objective of a thermal management system is to increase the performance and life of a battery by regulating its temperature. Although the consequences of deficient thermal management are not just reduced life cycle and performance and can be potentially life threatening.

In 2016, Samsung recalled all of its Galaxy Note 7 after it was discovered that the phone faced heating issues which resulted in a number of fires and explosions at the user end[16]. The fires were caused due to the excessive heating of the phone's battery during charging and the inability to properly regulate its temperature. The release of the Galaxy Note 7 and its subsequent recall cost the company approximately \$17 billion. In 2018, Toyota recalled more than 1 million of its plug-in Prius models as well as other C-HR SUV models over issues related to electrical/battery systems [17]. Previously, a hybrid Prius exploded in one the user's home after getting a battery replacement in California resulting in the user losing his house and all other belongings.

1.2 Thesis Objective

A good battery management system ensures the battery temperature stays within acceptable limits and prevents battery discharge beyond 30% State of Charge (SOC). Nonetheless, one can never predict untowardly situations. It is important to consider an alternative in the event of a system failure and provide for necessary backup. Thermal runaway is a serious issue in Li-ion batteries. Facilitated by increasing temperatures and current flow, thermal runaway can cause irreversible damage to the battery. Thermal runaway can cause batteries to explode and possibly injure the end user. Therefore, it is of paramount importance to design an effective thermal management system.

Thermal management strategies can primarily be divided into two categories; the first one is a more mechanical way of reducing the battery temperature by taking factors like its thermal resistance into consideration and the second method tackles the heat source directly by preventing the battery reach critical temperatures during operation. While mechanical cooling cannot be bypassed, a lot of research is being in the latter field to incorporate more electrical solutions to the thermal management problem. There are different ways of mechanical/resistance control to reduce battery temperature. Air cooling is widely used in Electric Vehicles as a means of cooling due to its low parasitic power consumption. The battery can also be immersed in Phase Change Materials (PCM) either directly or indirectly to prevent it from reaching high temperatures. The PCM has low melting low and high boiling point with high latent heat tolerance. Though an interesting technique, it is not widely used in EVs as the cooling is not uniform. Liquid cooling is the most popular method of cooling as it has the highest efficiency as compared to other methods. Liquid cooling is also used in several industrial applications other than EVs.

Although, mechanical methods of battery cooling are efficient, they are physical systems which occupy a lot of space in the system environment and have significant parasitic power consumption. Therefore, it is important to invent methods which reduce this parasitic power consumption without bulking up the system.

The main objective of this research is to deal with the thermal management problem by integrating supercapacitors into the Li-ion battery system as a means to reduce the battery temperature during operation by preventing the battery to reach high temperatures. The thesis aims to employ the hybrid battery-supercapacitor architecture as a means of thermal management.

1.3 Market Survey

From 2012 to 2016 the cost of manufacturing Li-ion batteries have reduced by 73%. It is estimated that in 2030, applications using Li-ion batteries other than Electric Vehicles will be approximately 11% [8]. Among the various types of Li-ion battery configuration, the 18650 cylindrical battery remains the most popular option. The approximate demand for materials to build the battery in 2019 was 19 kt (kilotons) for cobalt, 17 kt for lithium, 22kt for manganese and 65 kt for nickel. As the share of EVs increases in the market, the use of Li-ion batteries will also increase, and the estimated material use for the battery in 2030 is predicted as shown in the figure below.

Annual lithium and cobalt demand for electric vehicle batteries, 2019-30

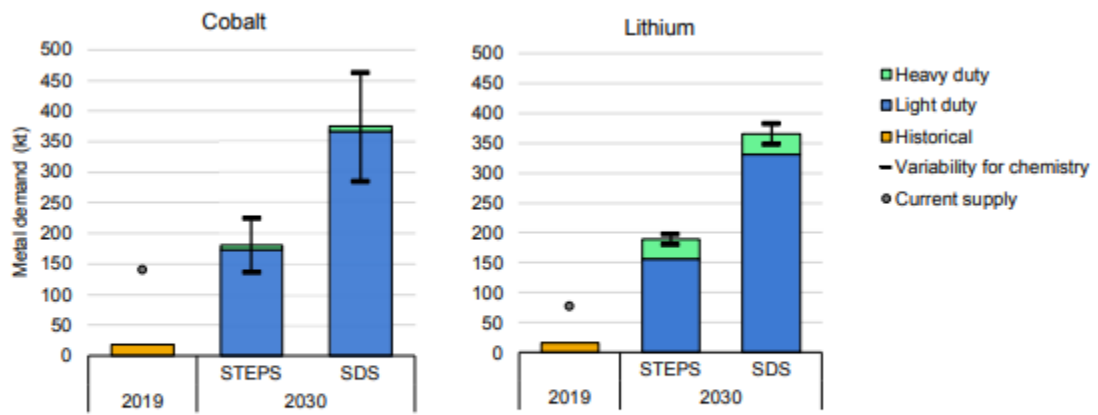

IEA 2020. All rights reserved.

Notes: kt = kilotonnes; STEPS = Stated Policies Scenario; SDS = Sustainable Development Scenario. Error bars show the variability arising from varying assumptions related to the development of future battery chemistries.

Figure 1.2: Amount of Cobalt and Lithium used for the Construction of EV batteries (Based on the report Global EV Outlook 2020 [8])

1.4 Literature Survey

The idea of building a thermal management system for batteries is not new. There has been a lot of research in the field of thermal management. A variety of methods are tried and tested to establish the efficiency of the cooling system. Some of the methods used for cooling are air

cooling, liquid cooling, cooling using Phase Change materials, cooling using heat pipes, etc. These methods deal with cooling the battery externally to prevent it from reaching hazardous temperatures. Although these various methods exist and are effective in lowering the temperature of the battery pack, they are preventive measures, not precautionary. A precautionary approach is preferred as appropriate measures are taken before the occurrence of an unpleasant incident as it always battery to avoid an accident than heal from it later. The main challenge for today's researchers is to build a system which prevents the battery from internally reaching critical temperatures during operation. This thesis adopts a precautionary approach than a preventive one as it focusses on preventing internal heat generation rather than cooling it externally. In the following paragraphs, a brief survey of the advancements in thermal management systems (both internal and external) are given.

Soltani et al. [7] proposed a thermal model for Li-ion capacitors which are valid up to 500A currents and can function in a wide temperature range. Li-ion capacitors aim to integrate the advantages of both Li-ion batteries as well as electric double-layered capacitors and erase their drawbacks. The working ambient temperatures for Li-ion capacitors are -20°C to $+60^{\circ}\text{C}$. These capacitors are extremely versatile and can be used for high energy applications as it has an energy density of 14Wh/Kg. It is perfect for power shaving and regenerative applications, although it is unfortunate, they don't capture the regenerative braking market as much. The researchers designed a first order and second order electrical equivalent model for the Li-ion capacitor. Through experiments they observed that the second order model was accurate up to 98% for smaller currents. They also designed a 1D thermal model with an error less than 5%. These results were first simulated and then later verified through experiments.

Karimi et al. [2] performed a comparative study between natural convection air cooling and forced convection cooling using dielectric silicone oil. Flat Li-ion batteries with ducts attached to the two opposite ends of the multi-cell pack was taken into consideration for the experiment. While studying natural convection air cooling, they observed that the maximum battery pack temperature did not exceed 39°C. But since it is natural convection, the air flow rate is very low resulting it extremely small heat removal. For the comparative study between natural convection air cooling and forced convection liquid cooling, one of the ducts was filled with the dielectric silicone oil while the other duct was to let air flow naturally through it. Results showed that the forced convection method was more effective than natural cooling. Although forced convection kept the battery temperature low, the high viscosity of the dielectric takes a huge amount of energy to pump into the ducts as well as the heat removal from the battery pack was not uniform. The proposed model is a distributed system with small channels across every 2 cells within the battery pack. Forced air cooling is the suggested cooling method. This technique consumed less power than forced liquid cooling but increases the volume of the battery pack by 14%.

Huang et al. [4] recommended the use of flexible form stable composite phase change material (CPCM) to use as a means of liquid cooling. Flexible form stable CPCMs are differ from traditional PCMs like paraffin as they do no melt or change flow rate upon application of heat. CPCMs can reduce battery temperature by 18°C at a constant discharge rate of 7A. It was observed that flexible CPCMs have lower thermal contact resistance as compared to traditional PCMs and CPCMs. For small power levels the ideal phase change temperature is 33°C while for higher power levels it is 47°C. The usage time of the battery pack in a typical application increased due to the use of flexible CPCM. Even at high ambient temperature, flexible CPCMs provide significant cooling and experimental data agrees with the numerical model of the system.

Greco et al. [5] suggested the use of heat pipes for thermal management of Li-ion batteries. A heat pipe is a pipe having two sections; one for the heat side and the other is the condensation side. The pipe has a liquid medium which absorbs heat from the hot surface of the battery. As the temperature of the liquid medium rises, it evaporates and moves to the cooler section of the pipe and condenses. Once the condensation is completed, the liquid travels back to the heat side through capillary action. Heat pipes have a high contact surface and the maximum temperature of the battery pack was observed to be 27.6°C while it was 51.5°C when forced convection was used. The reduction in liquid level at the heat side and the effect of gravity on the movement of the liquid inside the pipe was ignored. The proposed model is not efficient in an application where the size of the heat pipes would be critical.

Qian et al. [3] proposed a liquid cooling method using mini channel cold plates where the mini channels would be placed between 2 batteries in a multi-cell battery pack. A number of parameters such as number of channels, inlet mass flow rate, flow direction, width of channels, etc. were taken into consideration. The effects due to the changes in the different parameters were studied and 3D thermal model was designed. The model showed good cooling at a discharge rate of 5C. The cold plate touches the surface of the battery and the heat transfers to the liquid medium through the mini channels. Only 2 mini channels can keep the maximum battery temperature under 40°C for more than half the discharge time. Through experimentation, it was observed that a 5 channel cold plate was sufficient for thermal management and increasing the mini channels more than 5 achieved no significant reduction in battery temperature.

Zhao et al. [6] discuss the effects of changing physical characteristics of the battery in order to reduce internal heat generation and systematic thermal management models to directly tackle with external heat dissipation. For external heat removal a number of methods such as air cooling,

liquid cooling using dielectric materials and PCMs, heat pipes, etc. were tested. The experiments concluded that forced air convection was the best method for cooling the battery due to low safety issues. IN case if indirect contact of the liquid medium with the battery pack, the thermal resistance increases, and hence additional measures need to be undertaken to deal with the same. The authors discussed electrode modification as a way of reducing internal heat generation as electrodes are responsible for maximum heat generation in a battery. Reducing the electrode thickness results in lower heat generation but it also means lower energy density of the battery. Electrode modification increases manufacturing costs significantly. Hence, it is not a practical approach.

Shin et al. [1] proposed a hybrid Li-ion battery-supercapacitor model as a means of thermal management. The supercapacitor is used in both power mode as well as idle mode. Idle period insertion strategy is where the battery is allowed to rest for a brief period of time while the power is drawn out from the supercapacitor. Since supercapacitors have high energy density, it is possible to deliver the required energy for the application without having a reduced current output. In the power mode, the power is drawn out from both the battery as well as the supercapacitor. Both the components of the hybrid model are charged together. The idle period insertion lasts for 20seconds during which only the supercapacitors comes into play. The reactive control strategy for the hybrid model provides exploits the parallel battery-supercapacitor arrangement efficiently while providing satisfactory thermal management. One of the main drawbacks of the proposed is that the heat generation of the supercapacitor is ignored. In practical applications, this is an important factor as if the need for thermal management of the supercapacitor arises, it makes the hybrid model redundant.

The methods of thermal management in the above literature survey are effective up to a degree and are even used in the industry. A major disadvantage of such methods is the parasitic

power usage of such thermal management systems. The battery system in an EV uses a significant amount of power to simply run the cooling system. Shin et al. tried to deal with the parasitic power consumption issue by employing the hybrid battery-supercapacitor architecture. It ignores the heat generation in the supercapacitor itself. Heat generation in the supercapacitor is an issue which cannot be ignored in practical applications. A separate system to cool the supercapacitor would be counterproductive. This thesis tries to design a thermal management system by using the hybrid architecture in a way which minimizes parasitic power consumption by the thermal management to lowest.

Chapter 2: Dynamic charging/discharging of the hybrid battery-supercapacitor for thermal management

2.1 Brief Overview of EV batteries

The fact that batteries are the heart of Electric Vehicles is irrefutable. The Battery Management System plays a pivotal role in the smooth and efficient functioning of the battery and ultimately the car. Yet, the batteries used in all commercial EVs are not the same. Different manufacturers use batteries of different construction and specifications. The battery energy capacity, battery type, cooling system used for thermal management, etc. all decide the mileage, charging time and longevity of its use. The construction of the battery cell is a key factor in determining the subsequent battery management system. Batteries of construction types such as cylindrical, prismatic, pouch are used for commercial EVs [13]. The table(2.1) illustrates some EVs and HEVs and their respective battery specifications.

Table 2.1: Various car models and their respective battery specifications

Car Model	Battery Type	Battery Capacity	Miles covered	Charge time
Toyota Prius (PHEV)	Li-ion	4.4KWh	11	3hr-115V-15A 1.5hr-230V-15A

Table 2.1 (continued)

Chevy Volt (PHEV)	Li-Mn	16KWh	40	10hr-115V-15A 4hr-230V-15A
Smart Fortwo ED	Li-ion 18650 cells	16.5KWh	85	8hr-115V-15A 3.5hr-230V-15A
BMW i3	LMO/NMC (prismatic)	42KWh	175	4hr-11KW-AC 30min-5KW- DC
Tesla S	Li-ion 18650 cells (3.4Ah)	90KWh	265	12KW supercharger; 80% in 30mins
Tesla 3	Li-ion 18650 cells (3.4Ah)	75KWh	310	11.5KW-AC 30mins - DC

Prismatic cells used in the BMW i3 models are born from the need to develop batteries with smaller sizes. Their compact structure enables them to have high energy density with relatively small volume. They use layered approach for its construction i.e., the anode and cathode materials are in the form of thin sheets sandwiched with a separator between them in a housing of hard plastic or metallic casing. A battery housing is essentially a physical component used to encase the battery from exterior factors. Prismatic cells are generally used in applications such mobile phones and laptops and their capacity range is typically within 800mAh to 4000mAh. There are large format prismatic cells with capacities up to 20-25Ah which are used in HEVs and EVs. Large format prismatic cells typically come in aluminum housing. Although, an extremely optimal volume is achieved through prismatic cells, its thermal management is much more complicated especially in large format batteries.

Pouch shaped Li-ion batteries from manufacturers such as GeePower, DNK Power, etc are gaining popularity due to its non-typical construction. Pouch batteries have conductive foil like tabs welded to the electrode material instead of using a glass to metal electrical feed through. The most basic advantage of using pouch batteries are that they are flexible and light weight. Pouch batteries have a packing efficiency of 90-95% which is the highest among all other types of batteries. However, this super compact packing comes at a price. Pouch batteries tend to swell due the release of electrode gases under high load. For this reason, they should not be stacked on top of each other and space some be kept to account for the swelling. Commercial pouch batteries come with built in gas bags. Large format pouch cells have a capacity of 40Ah. Pouch cells have been used in EVs but their application is not very popular since there is not industry standard in place for its manufacturing and its specifications are mostly left at the discretion of its manufacturers. Whilst prismatic and pouch cells may not be able to have the same advantages as a cylindrical cell, their technology is improving exponentially.

Cylindrical Li-ion cells are the most popular and widely used batteries in the industry. They are easy to manufacture and have good mechanical stability. Some cylindrical Li-ion batteries (Panasonic NCR18650B, Sanyo NCR18650GA, etc) contain a positive thermal coefficient (PTC) switch. When the current increases beyond a certain limit, the temperature of the cell rises. This leads to the PTC switch turning resistive, stopping the current flow and essentially acting as a short circuit protection. As the battery cools down, the PTC switch returns to being conductive again. Some commercial Li-ion batteries have a built-in Charge Interrupt Device (CID) which disconnects the cell physically when the pressure build-up is unsafe. This process is irreversible, and the battery can no longer be used.

The negative and positive electrodes of a Li-ion battery are made of carbon and metal-oxide (i.e. CoC_2), respectively. The electrolyte is typically a lithium salt immersed in an organic solvent. The chemical reaction taking place inside the cell generates a large amount of heat. The chemistry of the Li-ion battery, considering the positive electrode to be lithium dope cobalt oxide, is shown below [10].

- An oxidation half reaction at the anode produces positively charged lithium ions and negatively charged electrons during discharging.

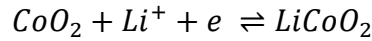

- Lithium ions and the electrons combine at the cathode during the reduction half reaction.

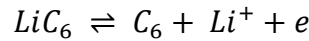

- The full reaction is given by,

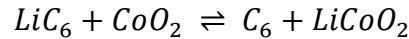

- An irreversible reaction takes place when the battery is over-discharged as the lithium cobalt oxide produces lithium oxide.

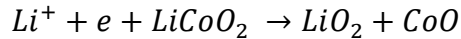

- Overcharging leads to the concoction of cobalt (IV) oxide.

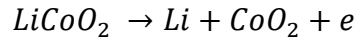



Figure 2.1: Electric Vehicle's battery module arrangement on the chassis [20]

The figure 2.1 shows Li-ion battery arrangement on an EV chassis. The unit between two orange terminals make for a single battery module. An EV battery system is made up of multiple battery modules and each battery module is made of multiple cells. Voltages are determined to be high voltages if they exceed 60V if DC and 30V if AC. A battery cannot directly store AC energy. For a battery to deliver AC, the battery changes polarity of the supply for every half cycle of the duration. This is not feasible for EVs, hence all EV batteries are DC batteries. Each battery module voltage is maintained in a way that their terminal voltage is always less than 60V DC [12]. From Table 2.1 we can see that electric vehicle batteries have an energy that ranges between 2kWh to 20kWh for PHEVs and 30kWh to 160kWh for EVs. As $P=VI$, to achieve high power for a desired voltage (i.e., 60V) the battery system should be able to deliver high currents.

To achieve the desired voltage in the batteries, cells are connected in series in the battery modules. For the safety of the use, batteries are equipped with battery management systems that has a feature for over-voltage protection. The idea behind any coherent battery management system is to increase performance and reduce loss. Battery current needs to be conducted from one

part of the vehicle to another through wires. If the current is to be increased, it leads to increase in IR losses as,

$$P_{loss} = I^2 R_{pack}$$

In contrast to batteries, which delivers a steady flow of energy, supercapacitors have a linear discharge curve. Supercapacitors are double layered capacitors with extremely high values of capacitance. Their capacitances range in Farads whereas typical electrolytic capacitors range in micro-Farads. Supercapacitor's voltage range typically lies in 2.5-2.7V. In order to achieve higher voltage range, multiple supercapacitors have to be connected in series. This is not a foolproof idea as it increases internal resistance and reduces the capacitances of the supercapacitors. But there are exceptions, such as the ELNA supercapacitors which have a voltage range of 5.5V for some low values of capacitance. The voltage supplied by a battery depends on the electrochemical reactions taking place inside the battery, whereas in a supercapacitor it depends on the formation of electric double layers from the ionic electrolyte of opposite polarity to the two electrodes polarity. Supercapacitors are sometimes also known as ultracapacitors and their energy density lies in the range 1Wh/kg to 20Wh/kg which is much lower than a typical Li-ion battery. Hence, supercapacitors cannot be completely used as an alternative for Li-ion batteries. One of the main advantages of supercapacitors is that they have an incredible life cycle, reducing their capacity from 100% to 80% in 10 years. Unlike batteries, the longevity of their use is not dependent on the number of cycles run.

2.2 Basic Framework and Hypothesis

The voltage across a battery module is at a constant high voltage (below 60V DC), therefore depending on the speed, road condition, load on the EV, etc. the current supplied from these battery modules varies. As the current increases, the internal temperature of the battery also increases. This increase in internal temperature causes the battery to release more energy than necessary, resulting in an even more rise in battery temperature. The situation eventually leads to thermal runaway of the battery which is similar to an uncontrolled positive feedback loop. Thermal runaway is caused by an exponential rise in battery temperature, yet it is not the only reason for it. Discharging the battery to more than 70% of its State of Charge (SOC) can also lead to a dangerous increase in temperature, subsequently leading to thermal runaway. As mentioned earlier, Thermal runaway can lead to battery explosions under uncontrolled conditions. Various battery-supercapacitor based hybrid architectures have been explored in the past to improve the efficiency of the discharge process of the battery. The most common architecture is the passive parallel connection where the battery connected directly in parallel with the supercapacitor. The parallel connection aides a higher discharge performance owing to the high energy density of the battery. In previous works, this arrangement has been exploited in only energy storage applications [19]. This thesis aims to employ the parallel battery-supercapacitor architecture for thermal management.

The objective of the current research is to study the feasibility of using an axillary supercapacitor to manage the temperature raise in a Li-ion battery via controlling the battery current. The hypothesis contrived states that the temperature of the battery can be controlled by reducing the current delivered to the load by the battery and fulfilling the deficit current from an auxiliary supercapacitor.

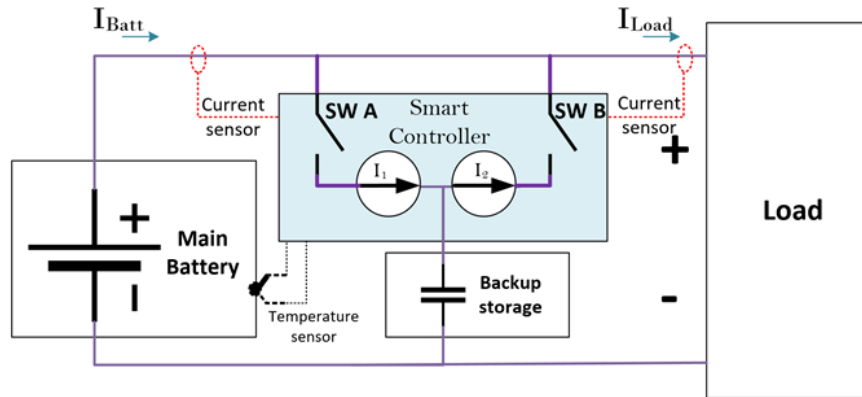

Figure 2.2: Schematic diagram of the test circuit

The supercapacitor will be charged by the battery prior to its involvement in the discharge process. In the system under consideration, the supercapacitor is connected in parallel to the battery through a switch. The battery charges the supercapacitor to store enough charge to supply back when needed. Additionally, the supercapacitor is also charged by absorbing the excess off the battery in case of overcharging, thus acting as a bypass. As the internal temperature of the battery rises beyond a certain limit, the current being supplied from the battery to the load is reduced for a short amount of time. The current deficit is fulfilled by the supercapacitor for that short period of time. Reducing the current supplied by the battery should allow for the battery to cool off and avoid the internal temperature to rise above critical limits. Internal temperatures of the battery can rise as high as 200°C leading to electrode decay and eventual explosion. The ideal temperature for battery discharge ranges from -20°C to +60°C. As the temperature of the battery is stabilized, the supercapacitor charges again. The battery-supercapacitor discharge-charge cycle repeats itself until the system is still under operation.

2.3 Hypothesis Review

For the sake of experimentation a single Panasonic 18650 cell of 3.4Ah is considered. The nominal voltage of the battery is 3.6V, maximum voltage is 4.2V, weighs 48.5g and has an energy density of 243Wh/kg [15].

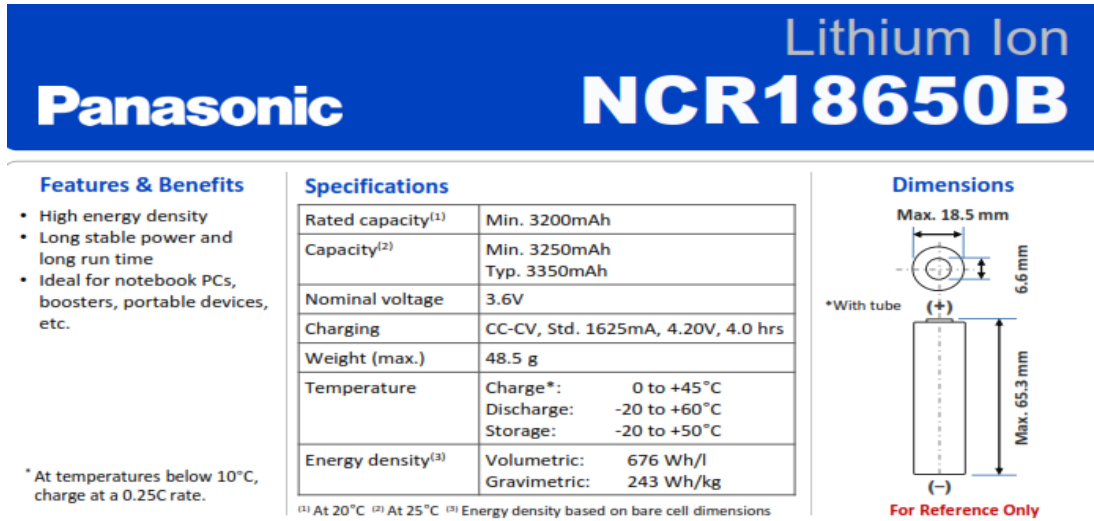

Figure 2.3: Datasheet of the Panasonic NCR18650B

The battery is discharged under a constant load ranging from 1.6A – 2.4A at an incrementation of 0.2A. In the hybrid battery-supercapacitor architecture, the battery first charges the supercapacitor and the supercapacitor delivers back the current when the load on the battery is reduced. We assume an additional 0.2A added to the battery discharge current in order to charge the supercapacitor for a time interval of t_1 . When the temperature of the battery rises and the supercapacitor kicks in, the amount of current supplied by the battery is reduced by 0.2A and the deficit is covered by the supercapacitor. Battery parameters such as internal power loss, temperature rise, and charge supplied are directly dependent on the load current and time under load. Therefore, it can be said these parameters are reflective of the internal state of the battery and hence will be computed to determine the success of the proposed method. The physics behind computing the battery parameters are given below:

- The temperature constant which is defined as the amount of rise in temperature per watt is given by,

$$t_{au} = -m * C_{therm} * R_{therm}$$

where, $m \rightarrow$ is the mass of the battery

$C_{therm} \rightarrow$ is the thermal capacity or specific heat of the battery

$R_{therm} \rightarrow$ is the thermal resistance of the battery

- Total charge supplied by the battery,

$$Q_0 = t * I_0$$

where, $t \rightarrow$ is the time under load

$I_0 \rightarrow$ is the constant current delivered by the battery to the load

- Power loss due to internal resistance P_0 is given by,

$$P_0 = R_{in} * I_0^2$$

where, $R_{in} \rightarrow$ is the internal resistance of the battery

- Energy loss,

$$E_0 = t * P_0$$

- Rise in battery temperature,

$$temp_0 = P_0 * R_{therm} * (1 - e^{-\frac{t}{t_{au}}})$$

- The time under load is divided into 2 fractions: t_1 is the time for which the battery delivers current to the load and also charges the supercapacitor, t_2 is the time during which the current delivered by the battery is reduced and the supercapacitor supplies the remaining required amount of current.

$$i_1 = I_0 + I_{c1}$$

$$i_2 = I_0 - I_{c2}$$

$$t_1 = t * \frac{I_{c2}}{I_{c1} + I_{c2}}$$

$$t_1 = t * \frac{I_{c2}}{I_{c1} + I_{c2}}$$

Where I_{c1} & I_{c2} are additional currents supplied by the battery and supplied to the battery from the supercapacitor, respectively.

- The charge in the battery, power loss, energy loss and battery temperature for the duration of t_1 are given by,

$$Q_1 = i_1 * t_1$$

$$P_1 = R_{in} * i_1^2$$

$$E_1 = P_1 * t_1$$

$$temp_1 = P_1 * R_{therm} * (1 - e^{-\frac{t_1}{\tau_{au}}})$$

- The charge in the battery, power loss, energy loss and battery temperature for the duration of t_2 are given by,

$$Q_2 = i_2 * t_2 + i_1 * t_1$$

$$P_2 = R_{in} * i_2^2$$

$$E_2 = P_2 * t_2 + P_1 * t_1$$

$$temp_2 = P_2 * R_{therm} * \left(1 - e^{-\frac{t_2}{\tau_{au}}}\right) + P_1 * R_{therm} * (1 - e^{-\frac{t_1}{\tau_{au}}})$$

Changes in battery temperature due to convection and radiation are ignored as the battery is considered to be in a controlled environment with no influence due to external factors. Based on

the equations discussed above, a MATLAB model was built to analyze the performance of the hypothesized system based on true values. The inputs given to the model were [9]:

Table 2.2: Input parameters for the hypothesis model

Description	Symbol	Value
Internal Resistance of the battery (ohms)	R_{in}	0.055
Constant current delivered by the battery to a load (A)	I_0	1.6A-2.4A
The current to charge the supercapacitor at during t1 (A)	I_{c1}	0.2A
The current that supplies back from the supercapacitor during t2 (A)	I_{c2}	0.2A
Time of being under the load (seconds)	t	*varies*
Mass of battery (Kg)	m	0.0485
Thermal capacity of the battery (J/Kg.K)	C_{therm}	941
Thermal Resistance (K/W)	R_{therm}	287.36

To further calculate the time required for discharge of the battery we assume linear discharge correlation and 100% battery SOC discharge. A 3.4Ah Li-ion battery takes one hour (3600 seconds) to completely discharge under constant load current of 3.4A. Therefore, the amount of time taken to discharge the battery completely under different load currents is as follow:

Table 2.3: Time taken for total discharge at different settings of the electronic load

Constant current supplied to the load	Time taken for complete discharge of battery
1.6A	7650 seconds
1.8A	6800 seconds

2.0A	6120 seconds
2.2A	5564 seconds
2.4A	5100 seconds

2.4 Hypothesis Results

The results from the hypothesis calculations were plotted for load current values ranging from 1.6A-2.4A at an interval of 0.2A. Ideal conditions were assumed for the functioning of the battery and its temperature curve was plotted.

The temperature curves show convergence. Beyond the point of convergence, the values of the red-blue curve are only going to be lower than the green curve. This proves that the hybrid battery-supercapacitor architecture is effective. In practicality the point of convergence will occur much sooner the supercapacitor won't be charging for the entirety of the red-curve period and hence, the projection of the red curve up on the green curve will be much smaller.

In figure(2.4)(a), the constant discharge current is set at 1.6A. An additional current of 0.2A is added to indicate the total load on the battery for charging the supercapacitor. During time t_2 , the load is 0.2A lower than 1.6A as the deficit is being supplied by the supercapacitor. For figure(2.4)(b), the constant discharge current is set at 2.4A and the increment in current for charging and reduction in load current during supercapacitor integration is 0.4A.

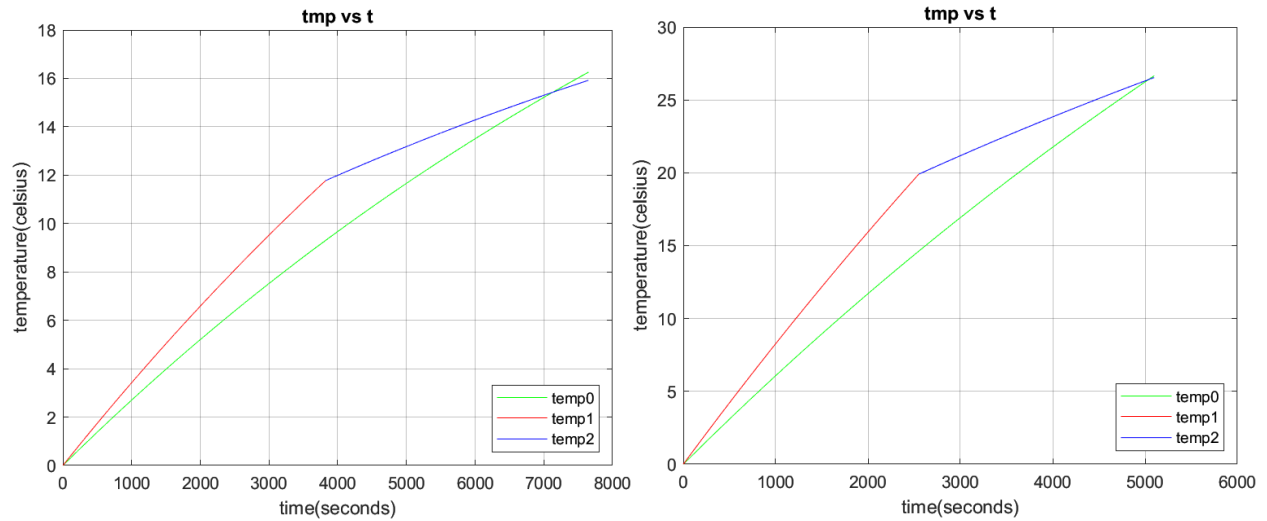

Figure 2.4: Temperature curve of the battery for (a) constant discharge of 1.6A and a reduction of 0.2A during supercapacitor participation (b) constant discharge of 2.4A and a reduction of 0.4A during supercapacitor participation

From the figures we can see that the temperature convergence is true for low values of discharge current as well as high. Despite the battery having to supply more current in case (b), the temperature decreases by a considerable value during supercapacitor participation.

Chapter 3: Thermal Behavior of Li-ion batteries

3.1 Experimental Setup

The experiment setup was designed in the simplest possible way to understand the thermal performance of the battery under constant and alternating loads. The goal of this experiment is to practically observe the maximum value of the battery temperature under different values of constant current delivered by the battery to the load and also estimate the behavior of the hybrid battery-supercapacitor architecture. The components used for the construction of the experiment are:

Table 3.1: Components used for the test setup

Commercial label	Component
Panasonic NCR18650B	Li-ion battery
DS18B20	Digital Temperature sensor
ACS712 20A	Hall-effect Current sensor
DROK load tester	Electronic Load

The electronics load tester is capable to sinking currents up to 5A. The hall-effect current sensor is essentially a digital ammeter which reads the current flowing from the battery to the load. The digital temperature sensors are physically connected to the body of the battery with the aid of

thermal conducting tapes which do not interfere with the temperature sensing capabilities of the sensor.

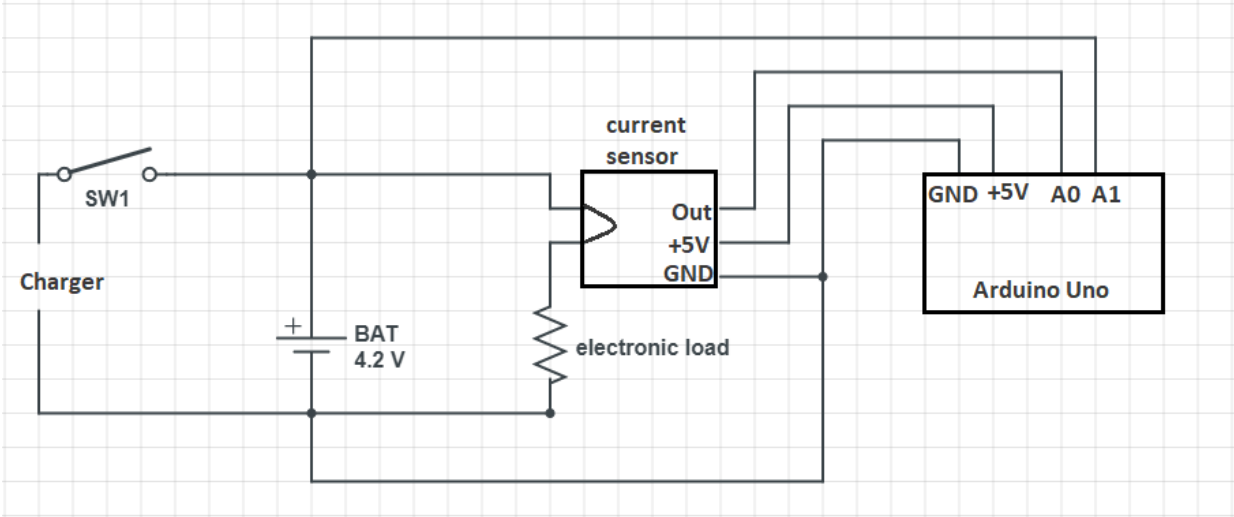

Figure 3.1: Circuit diagram of the test setup

The Vdd of the temperature sensors and the Vdd of the current sensor and connected together to the +5V pin and the GND pins are collectively connected to the GND (ground) pin of the Arduino Uno. Since the DS18B20 is a one wire sensor, all four DQ pins can be connected to the same A5 pin of the Arduino Uno. The body of the battery along with the connected temperature sensors was enclosed in a clear plastic box to prevent the changes in ambient temperatures affect the battery temperature or record accurate readings on the sensor.

The voltage of the battery being sensed at the A0 pin is analog in nature. To convert the signal into meaningful data, we perform the following calculation,

$$Vol = AnalogRead(A5); \dots\dots\dots(1)$$

$$Voltage = vol * \left(\frac{5}{1023}\right) \dots\dots\dots(2)$$

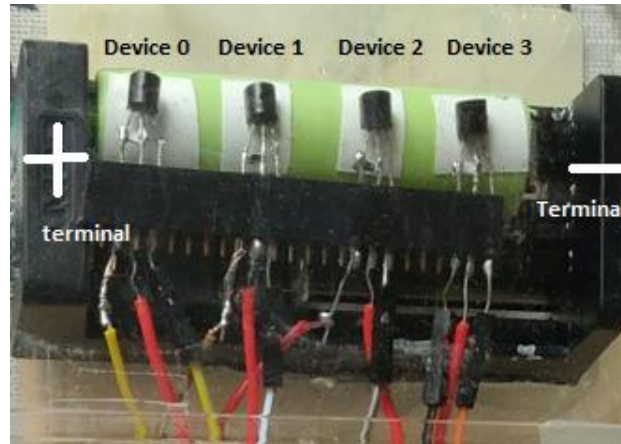

Figure 3.2: Placement of the temperature sensors on the battery body

The voltage, current and temperature readings were recorded at an interval of 60s. This was done until total discharge of the battery. A single cycle includes charging the battery to 4.2V and discharging it at a constant current load value. After total discharge, the battery was allowed to rest until it returned back to room temperature.

3.2 Results and discussion

3.2.1 Constant current discharge of the battery

The battery was discharged to approximately less than 10% of SOC. The temperature, voltage and current supplied by the battery was observed. The 3 parameters were noted for batteries current ranging from 1.6A to 2.4A. As observed from the results, the temperature of the battery increases as the current that needs to be delivered to the load increases. The mechanism behind this observation is that, for the battery to deliver power, the electrons move from the negative terminal of the battery to the positive terminal.

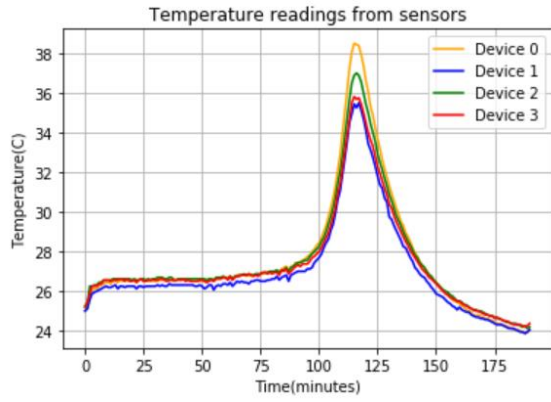

(a)

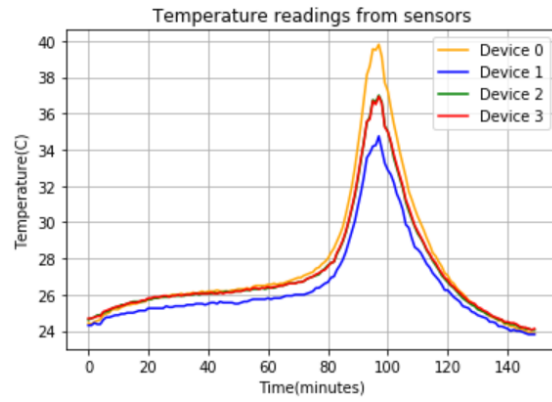

(b)

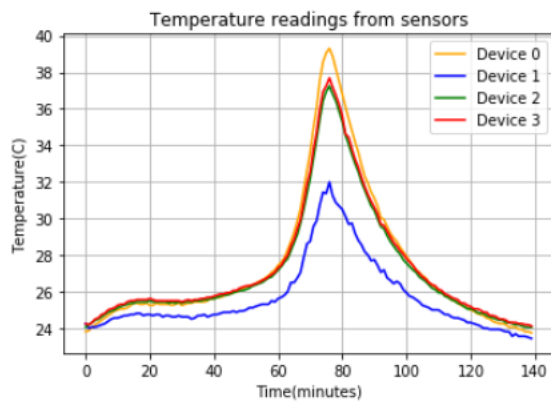

(c)

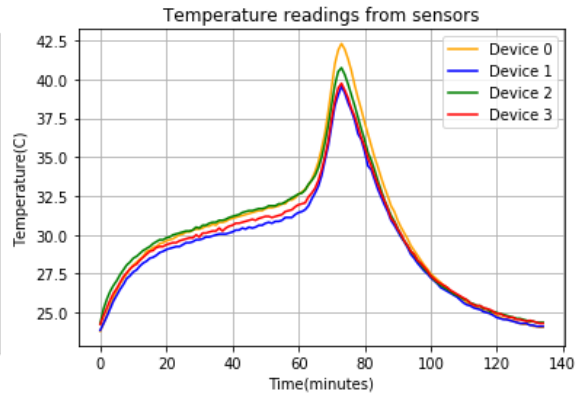

(d)

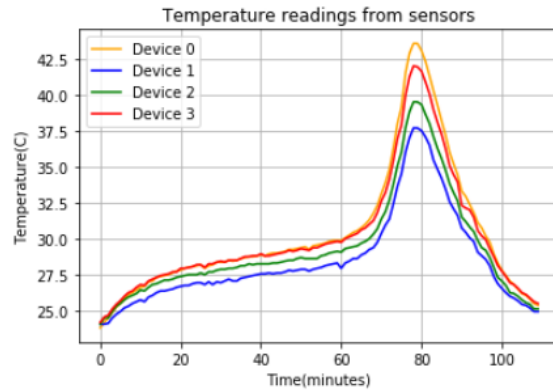

(e)

Figure 3.3: Temperature curves for constant discharge current setting (a) 1.6A (b) 1.75A (c) 2.0A (d) 2.2A (e) 2.4A

The electronics load ensures the delivery of constant power, hence, as the current that needs to be delivered increases, the reactions taking place inside the battery to deliver the required power increases. There is considerable amount of heat generated due to the power loss owing to the internal resistance of the battery. The exponential increase of the temperature is due to thermal runaway. Once the battery undergoes thermal runaway, the electronic load is immediately (manually) disconnected and separated from the discharge module. It is then charged so as to avoid the internal chemistry of the battery from remaining in the same state it was during thermal runaway. Failure to take necessary precautions as during thermal runaway can lead to even more increase in battery temperature eventually causing it to explode. When a battery pack of multiple cells in applications such as EVs in undergoing thermal runaway the danger can be life threatening. The consequences can range from complete irreversible failure of the battery pack to car explosion and loss of life.

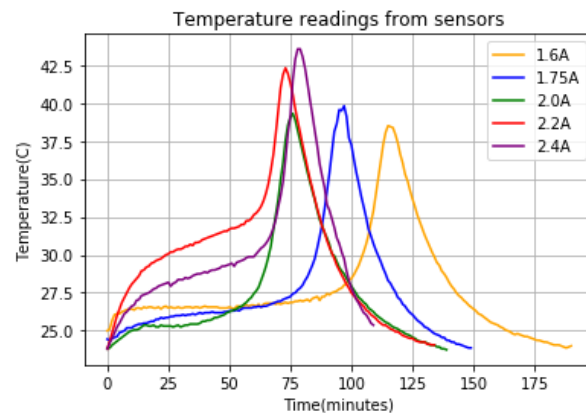

Figure 3.4: Comparison graphs for Device 0 at different constant current discharge values

Figure3.4 shows the temperature curves which shows the highest battery temperature for different settings of the load current. The amount of time taken for total discharge of the battery is lower than the one calculated in the hypothesis. The positive feedback effects of thermal runaway

can be verified using the above graph. As heat generation leads to more energy consumption of the battery, the total discharge time also reduces.

3.2.2 Simulation of the effects of the supercapacitor

The supercapacitor affects the performance of the battery in two situations: 1.) When the battery needs to supply additional current to charge the supercapacitor 2.) When the current being delivered by the battery is reduced and the deficit is fulfilled by the supercapacitor. To simulate the effects of the supercapacitor on the battery, the current settings of the electronic load was increased and reduced by 0.2A to replicate the actions of charging the supercapacitor and reducing the current required to be delivered by the battery, respectively. The purpose of this test to understand the thermal behavior of the battery and the changes in temperature gradient upon the application of the supercapacitor. Hence, the current settings were alternated once the battery was discharged to 3.5V. It is around this voltage that the battery reaches almost 30% SOC and further discharge leads to exponential increase in temperature. Since thermal runaway is inevitable, the effects in battery temperature are to be studied between 30% SOC and 10%SOC of the battery. Until the battery reaches 3.5V, it was constant current discharged. For further discharge, the current settings were alternated every 5 mins starting from incrementing the current by 0.2A and then reducing it.

The figure(4.5) shown below represents the temperature curves when the current delivered by the battery is alternating and when the current delivered is constant, respectively. Although the battery undergoes thermal runaway in both cases and the trends in increase of temperature are similar, there is a vast difference between the exact specifications of the curves. To closely

understand the distinction between curves (a) and (b) we will further analyze the temperature gradients by calculating the slopes at different instances.

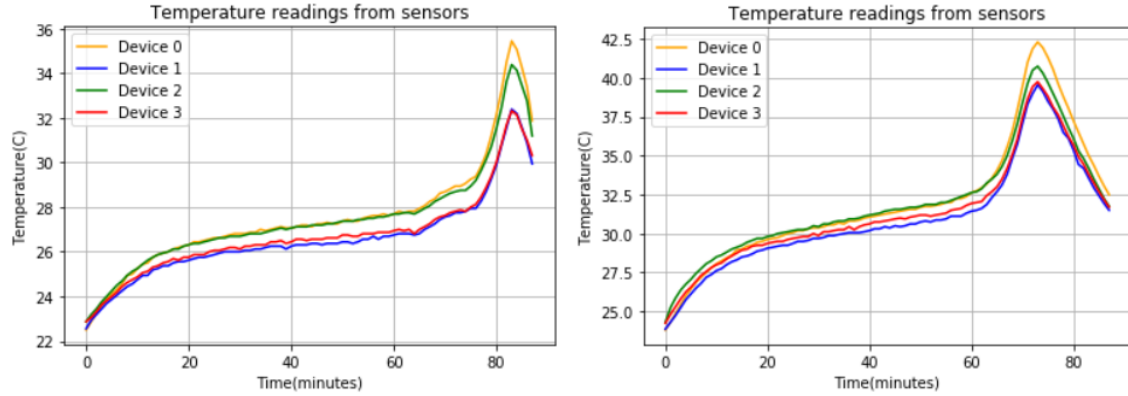

Figure 3.5: (a) Simulation of the battery upon supercapacitor integration (b) Battery temperature at constant current discharge of 2.2A

As observed, the maximum temperature of the battery when the hybrid battery-supercapacitor is employed is much lower than the maximum temperature of the battery when there is no supercapacitor involved. The maximum temperature value of curve (a) is 35.4°C whereas the maximum temperature value of curve (b) is 42.3°C. The decrease in maximum temperature of the battery can play a significant role in robust systems as the internal temperature of the battery can now be prevented from reaching hazardous levels. There is a noticeable plateau from periods between 50min to 80min. As the battery voltage reaches 3.5V around 50min, the load current was switched from 2.4A to 2.0A every 5 min. The temperature curve plateau can be extrapolated as a direct result of the switching of load current to simulate the hybrid architecture.

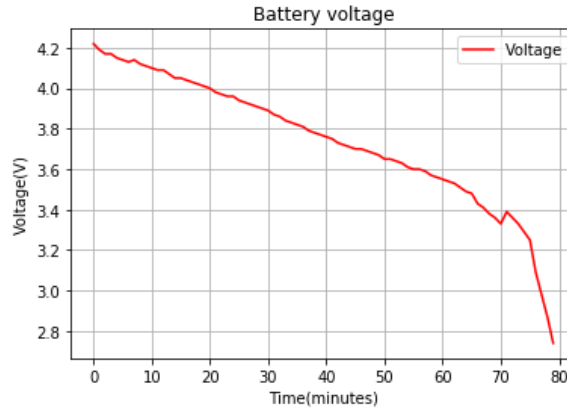

Figure 3.6: Voltage of the battery during supercapacitor simulation

Once the SOC of the battery reaches below 30% the temperature of the battery increasing exponentially. Since the time between 50min and 80min are our subject of analysis the temperature gradient calculations are computed for data points between those two instances only. The temperature gradient is nothing but the slope of the curves in graphs (a) and (b). The mean temperature gradient/slope between intervals 0-50min and 50-80min are:

Table 3.2: Mean slopes at different intervals for graphs 3.5 (a) and (b)

Intervals	Mean Slope for graph (a)	Mean Slope for graph (b)
0-50 minutes	0.0974	0.1576
50-80 minutes	0.1586	0.1853

The steeper the gradient the higher is the increase in temperature. The zoomed in images of the temperature curves shown in figure3.7 clearly demonstrate the difference in the curves.

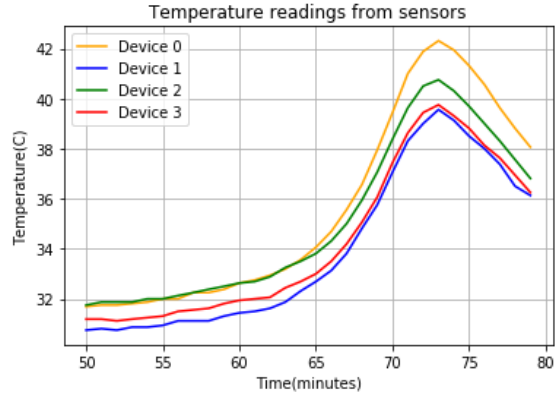
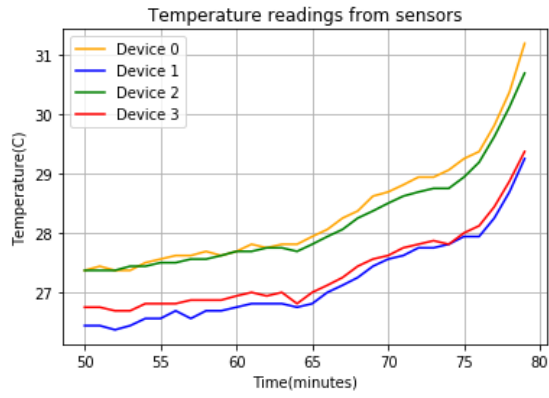

Figure 3.7: Zoomed images of the slope of graphs 3.5(a) and 3.5(b)

Chapter 4: Conclusion and Future Works

4.1 Conclusion

This thesis reviewed different methods of thermal management of Li-ion batteries, addressed the conditions under which thermal runaway occurs and designed a precautionary strategy to avoid battery temperature escalations reach critical levels. The battery-supercapacitor hybrid architecture has a well-documented history of efficient performance especially in hybrid energy storage system applications. While current thermal management technologies employ physical methods of battery cooling, the method detailed in this thesis makes use of the hybrid architecture to regulate the current being delivered by the battery as a means of controlling its internal heat generation.

The battery was discharged at different levels of load current. The discharge profile gave us an idea about the thermal profile of the Li-ion battery. We concluded that irrespective of the level of current being delivered by at the battery, thermal runaway would still occur if the SOC falls below 70% of its charge. The time taken for the battery to fully discharge is reduced as the current being delivered to the load increases. The actual time taken for discharge is lesser than the calculated time of discharge in the hypothesis due to the positive feedback nature of thermal runaway. The exponential increase in temperature during thermal runaway is used as an analysis point for the performance of the parallel connected supercapacitor.

The alternating load current strategy was used to simulate the supercapacitor performance. Overall, the temperature of the battery was controlled before inevitably rising due to thermal runaway. This method is efficient not only as an effective means of thermal management but in the event of a thermal runaway situation the system can immediately cut off from the battery and switch over to the supercapacitor for a brief period of time, thus allowing the application user to make informed decisions based on the situation. The lesser gradient of the temperature curves for the supercapacitor simulation test proves that the temperature did not increase as much as opposed to constant current discharge. The simulation results provide the proof of concept detailed in the hypothesis and verifies the approach taken to solve the thermal management issue.

4.2 Future Works

While there has been considerable amount of work done in the field of thermal management of Li-ion batteries, there are still plenty of avenues yet to explore. The need for an effective control strategy to ensure constant flow of power supplied from the supercapacitor to the load remains. A supercapacitor with a suitable value of capacitance is required to integrate with the battery system. As the power delivered by capacitors are linearly decreasing in nature, it is necessary to pair the supercapacitors with a DC-DC converter module. The DC-DC converter module helps establish a system to draw constant current out of the supercapacitor. Having an optimal capacitance supercapacitor ensures the required charge that needs to be delivered is present.

The development of machine learning has introduced new methods of system modeling. Using the data obtained through prognostic systems and combined with machine learning techniques like regression, it is possible to create a model to estimate the State of Charge of sa

battery without the need for additional and often complex machinery. By monitoring parameters such as voltage, current and temperature of the battery, the SOC can be estimated using regression algorithm by training a model with the data gathered. This is an incredibly powerful technique as it accounts for battery degradation over time. As the parameters return larger mean square error in comparison to the trained battery model, the Remaining Useful Life of the battery can also be computed.

There are various ways to approach any problem. Mechanical outlook focusses on thermal management methods such as air cooling, liquid cooling, use of PCMs, heat pipes, etc. These methods are heavily used in the automotive industry and have proven their purpose and efficiency when it comes to lowering the temperature of the battery through external means. Although these methods are more preventive in measure. For more precautionary measures, an electrical approach was more suited. The hybrid supercapacitor-battery architecture was successful in reducing internal battery temperature and provided an alternative energy storage in the event of a thermal runaway. Aside from these tow techniques, it would be interesting to see what the advances in material science can present us with. Breakthrough in the field of construction of supercapacitors can render a much higher energy density and energy storage capabilities. This can pave way for reduction in linear decrease of capacitor energy and increase in a more constant delivery of power. Increase in storage capacity of supercapacitors can propel thermal management and thermal runaway preventive strategies into another dimension.

A battery management system is only as good as the components that are used to build the system. A system cannot be ideal if the individual components are defective. An excellent thermal management system can be ineffectual if the battery itself does not deliver satisfactory performance. Therefore, advances in the construction of the battery are equally important.

Improvements in materials for battery development could lead to more energy density, lower internal resistance, and higher resistance to changes in ambient temperature. Lowering the internal resistance of the battery lowers the power loss within the battery and can also significantly lower internal heat generation. Reduced internal generation is great for improving battery performance.

Given capacitor discharge pattern and the control strategy proposed, we plan to design a DC-DC converter to enhance supercapacitor performance. The aim of this is to regulate the current being discharged by the supercapacitor. Based on these test results, the optimal capacitance supercapacitor will be integrated into the battery system to evaluate its performance in a more robust application. The results and observations obtained through the course of this thesis is a crucial step in moving forward with the further development of the thermal management system.

References

1. D. Shin, M. Poncino and E. Macii, "Thermal Management of Batteries Using Supercapacitor Hybrid Architecture With Idle Period Insertion Strategy," in *IEEE Transactions on Very Large Scale Integration (VLSI) Systems*, vol. 26, no. 6, pp. 1159-1170, June 2018, doi: 10.1109/TVLSI.2018.2818758.
2. Karimi, G. and Li, X. (2013), Thermal management of lithium-ion batteries for electric vehicles. *Int. J. Energy Res.*, 37: 13-24. <https://doi.org/10.1002/er.1956>
3. Zhen Qian, Yimin Li, Zhonghao Rao, Thermal performance of lithium-ion battery thermal management system by using mini-channel cooling, *Energy Conversion and Management*, Volume 126, 2016, Pages 622-631, ISSN 0196-8904, <https://doi.org/10.1016/j.enconman.2016.08.063>.
4. Yi-Huan Huang, Wen-Long Cheng, Rui Zhao, Thermal management of Li-ion battery pack with the application of flexible form-stable composite phase change materials, *Energy Conversion and Management*, Volume 182, 2019, Pages 9-20, ISSN 0196-8904, <https://doi.org/10.1016/j.enconman.2018.12.064>.
5. Angelo Greco, Dongpu Cao, Xi Jiang, Hong Yang, A theoretical and computational study of lithium-ion battery thermal management for electric vehicles using heat pipes, *Journal of Power Sources*, Volume 257, 2014, Pages 344-355, ISSN 0378-7753, <https://doi.org/10.1016/j.jpowsour.2014.02.004>.

6. Rui Zhao, Sijie Zhang, Jie Liu, Junjie Gu, A review of thermal performance improving methods of lithium ion battery: Electrode modification and thermal management system, *Journal of Power Sources*, Volume 299, 2015, Pages 557-577, ISSN 0378-7753, <https://doi.org/10.1016/j.jpowsour.2015.09.001>.
7. Mahdi Soltani, Lysander De Sutter, Jan Ronsmans, Joeri van Mierlo, A high current electro-thermal model for lithium-ion capacitor technology in a wide temperature range, *Journal of Energy Storage*, Volume 31, 2020, 101624, ISSN 2352-152X, <https://doi.org/10.1016/j.est.2020.101624>.
8. IEA (2020), *Global EV Outlook 2020*, IEA, Paris <https://www.iea.org/reports/global-ev-outlook-2020>
9. Keil, Peter, Katharina Rumpf, and Andreas Jossen. "Thermal impedance spectroscopy for Li-ion batteries with an IR temperature sensor system." In *2013 World Electric Vehicle Symposium and Exhibition (EVS27)*, pp. 1-11. IEEE, 2013.
10. Bergveld, H. J.; Kruijt, W. S.; Notten, P. H. L. (2002). *Battery Management Systems: Design by Modelling*. Springer. pp. 107–108, 113. ISBN 978-94-017-0843-2.
11. Dhameja, S (2001). *Electric Vehicle Battery Systems*. Newnes Press. p. 12. ISBN 978-075-06991-67.
12. C. Linse, R. Kuhn, 10 - Design of high-voltage battery packs for electric vehicles, Editor(s): Bruno Scrosati, Jürgen Garche, Werner Tillmetz, In *Woodhead Publishing Series in Energy, Advances in Battery Technologies for Electric Vehicles*, Woodhead Publishing, 2015, Pages 245-263, ISBN 9781782423775, <https://doi.org/10.1016/B978-1-78242-377-5.00010-8>. (<https://www.sciencedirect.com/science/article/pii/B9781782423775000108>)

13. https://batteryuniversity.com/learn/article/electric_vehicle_ev

14. DS18B20 temperature sensor datasheet - <https://datasheets.maximintegrated.com/en/ds/DS18B20.pdf>

15. Panasonic NCR18650B datasheet - <https://www.batteryspace.com/products/specs/NCR18650B.pdf>

16. Samsung S7 Phone battery blasts - <https://web.archive.org/web/20160903223519/http://www.theverge.com/2016/9/2/12767670/samsung-galaxy-note-7-recall-fire-risk>

17. Toyota Prius PHEV Blast - <https://insideevs.com/news/317318/famous-toyota-prius-plug-in-conversion-catches-fire-then-explodes/>

18. Silberberg, M. (2006). Chemistry: The Molecular Nature of Matter and Change, 4th Ed. New York (NY): McGraw-Hill Education. p. 935, [ISBN 0077216504](https://www.mhhe.com/chemistry/silberberg/4e/).

19. Sunil Sreedhar, Jason B. Siegel, Saemin Choi, Topology Comparison for 48V Battery-Supercapacitor Hybrid Energy Storage System, IFAC-PapersOnLine, Volume 50, Issue 1, 2017, Pages 4733-4738, ISSN 2405-8963, <https://doi.org/10.1016/j.ifacol.2017.08.864>.

20. Jason Hughes, 057 Technology

Appendix A: Copyright Permission

The permission below is for the use of figures 1.1 and 1.2

Public use:

Subject to the **Exclusions** sub-section 3(e), you may reproduce Insubstantial Amounts of the Material in your own work and distribute your work to the public provided that: (a) your work does not generate revenue; (b) such reproduction is on an occasional basis; (c) anything greater than 5 (five) numerical data points (but still an Insubstantial Amount) from the Material must not be made available in a separate downloadable format and must be presented either in graphical format or aggregated (in such a manner that the reader cannot reverse engineer or extract the original underlying numerical data); (d) excerpts of non-data IEA Material, such as text, graphs and/or figures, must be reproduced in their entirety - only stylistic modifications to the excerpt's content are permitted; and (e) you must comply with the **Attribution** sub-section 3(b) below.

You are also permitted to produce and distribute, on a non-revenue generating basis, works based on or derived from no more than an Insubstantial Amount of the Material only, provided that such derived works: (a) are not primarily a copy of, or substitute for, part or all of the Material; (b) cannot be back-calculated, processed, translated, re-converted or re-engineered in any way in order to identify the underlying Material; (c) do not affect the IEA's ability to license part or all of the Material; and (d) clearly indicate that you, and not the IEA, produced the derived work.

If you wish to use the Material in a way that is not permitted above, please send us a rights request. Examples of non-permitted use include: selling the work in which Material is reproduced or which is derived from the Material; using the Material to produce and make available, free-of-charge or for a fee, databases that are substantially derived from the Material and/or could constitute a substitute for the Material; making more than 5 (five) raw data points from the Material, whether or not aggregated, available for download; using the Material to produce derived data for fee-paying clients; incorporating the Material in tools used to generate derived data for fee-paying clients; incorporating the Material in software distributed to fee-paying clients. Depending on the use you wish to make of the Material, the IEA may require you to enter into a separate licence agreement and charge you an additional fee.

Appendix B: Mathematical Model of the Hypothesis

```
clc
clear all
%% taking inputs from the user
R_sub1=input( ' Enter Internal Resistance of the battery (ohms) : ');
I_sub0= input(' Enter The constant current delivered by the battery to a load
(A) : ');
I_c1= input(' Enter The current to charge the supercap at during t1 (A) : ');
I_c2= input(' Enter The current that supplies back from the supercap during t2
(A) : ');
T_sub0=input( ' Enter Time of being under the load (seconds) : ');
m_sub1=input( ' Enter Mass of battery (Kg) : ');
c_sub1=input( ' Enter Thermal capacity of the battery (J/Kg.K) : ');
R_teta=input(' Enter Thermal Resistance (K/W) : ');

%% calculations
t= (0:1:T_sub0-1);
tau=-1*m_sub1*c_sub1*R_teta;
Q0= t*(I_sub0);

P0= (R_sub1)*(I_sub0)^2;
E0= t.*P0;
Temp0 = (P0*R_teta)*(1-exp(t./tau));

i1=I_sub0 + I_c1;
i2=I_sub0 - I_c2;
t1= T_sub0*I_c2/(I_c1+I_c2);
t2= T_sub0*I_c1/(I_c1+I_c2);
a=t(1:t1);
a2=t(t1+1:end);

if 0<=t<=t1
    Q1=i1*a;
    P1=R_sub1*i1^2;
    E1=P1*a;
    tmp1=(P1*R_teta)*(1-exp(a./tau));
    Temp2=(P1*R_teta)*(1-exp(t1/tau));
```

```

end

if t1<=t<=T_sub0
    Q2=i2*(a2-t1)+(i1*t1);
    P2=R_sub1*i2^2;
    E2=P2*(a2-t1)+P1*t1;

    tmp2=(P2*R_teta)*(1-exp((a2-t1)./tau))+Temp2*(exp((a2-t1)./tau));
end

plot(t,Q0,'g',a,Q1,'r',a2,Q2,'b')
title('Q vs t')
xlabel('time(seconds)')
ylabel('Q (Coulomb)')
legend('Q0','Q1','Q2','Location','southeast')

grid on
%% plotting results

plot(t,Temp0,'g',a,tmp1,'r',a2,tmp2,'b')
%%plot(t,Temp0,'g')
title('tmp vs t')
xlabel('time(seconds)')
ylabel('temperature(celsius)')
legend('temp0','temp1','temp2','Location','southeast')

grid on

plot(t,E0,'g',a,E1,'r',a2,E2,'b')
title('E vs t')
xlabel('time(seconds)')
ylabel('E(joules per second)')
legend('E0','E1','E2','Location','southeast')

grid on

```