USF Patents

May 2014

Dual-gas microcavity Raman sensor and method of use

Nicholas Djeu

Andreas Muller

Follow this and additional works at: http://scholarcommons.usf.edu/usf_patents

Recommended Citation

Djeu, Nicholas and Muller, Andreas, "Dual-gas microcavity Raman sensor and method of use" (2014). *USF Patents*. 121.
http://scholarcommons.usf.edu/usf_patents/121

This Patent is brought to you for free and open access by Scholar Commons. It has been accepted for inclusion in USF Patents by an authorized administrator of Scholar Commons. For more information, please contact scholarcommons@usf.edu.

(12) **United States Patent**
Djeu et al.

(10) **Patent No.:** **US 8,736,835 B2**
(45) **Date of Patent:** **May 27, 2014**

(54) **DUAL-GAS MICROCAVITY RAMAN SENSOR AND METHOD OF USE**

(71) Applicants: **Nicholas Djeu**, Tampa, FL (US);
Andreas Muller, Tampa, FL (US)

(72) Inventors: **Nicholas Djeu**, Tampa, FL (US);
Andreas Muller, Tampa, FL (US)

(73) Assignee: **University of South Florida**, Tampa, FL (US)

(*) Notice: Subject to any disclaimer, the term of this patent is extended or adjusted under 35 U.S.C. 154(b) by 0 days.

(21) Appl. No.: **14/080,283**

(22) Filed: **Nov. 14, 2013**

(65) **Prior Publication Data**
US 2014/0071446 A1 Mar. 13, 2014

Related U.S. Application Data

(63) Continuation-in-part of application No. 13/542,282, filed on Jul. 5, 2012, now Pat. No. 8,599,373.

(60) Provisional application No. 61/505,270, filed on Jul. 7, 2011.

(51) **Int. Cl.**
G01J 3/44 (2006.01)

(52) **U.S. Cl.**
USPC **356/301; 356/454**

(58) **Field of Classification Search**
CPC G01N 21/65; G01N 21/658; G01J 3/44
USPC 356/36, 244, 300-303, 311, 317, 318,
356/417, 451, 452, 454

See application file for complete search history.

(56) **References Cited**

U.S. PATENT DOCUMENTS

4,057,349 A *	11/1977	Barrett	356/45
4,648,714 A	3/1987	Benner et al.	
4,784,486 A	11/1988	Van Wagenen et al.	
5,255,067 A	10/1993	Carrabba et al.	
2004/0075845 A1 *	4/2004	Chang	356/519
2006/0183236 A1 *	8/2006	Berlin et al.	436/94

OTHER PUBLICATIONS

Kippenberg et al., Theoretical and Experimental Study of Stimulated and Cascaded Raman Scattering in Ultrahigh-Q Optical Microcavities. IEEE Journal of Selected Topics in Quantum Electronics. 2004. vol. 10 (No. 5): 1219-1228.

Li et al., Near-confocal cavity-enhanced Raman spectroscopy for multitrace-gas detection. Optics Letters. 2008. vol. 33 (No. 18): 2143-2145.

Linder et al., 900 mW continuous wave operation of AlInGaP tapered lasers and superluminescent diodes at 640 nm. Lasers and Electro-Optics. 2004: 900-901.

* cited by examiner

Primary Examiner — Tarifur Chowdhury

Assistant Examiner — Michael P LaPage

(74) *Attorney, Agent, or Firm* — Molly Sauter; Smith & Hopen, P.A.

(57) **ABSTRACT**

In accordance with the present invention, a dual-gas Raman sensor is provided that is based on an enhanced spontaneous dual emission as a result of cavity quantum electrodynamic effects. The dual-gas sensor includes a first reflector that exhibits a high reflectivity near the Raman shifted emission for the first species of interest and a moderate reflectivity near the Raman shifted emission for the second species of interest and a second reflector that exhibits a high reflectivity near the Raman shifted emission for the first species of interest and a moderate reflectivity near the Raman shifted emission for the second species of interest, allowing for the simultaneous measurement of the density of both the first species of interest and the second species of interest.

20 Claims, 3 Drawing Sheets

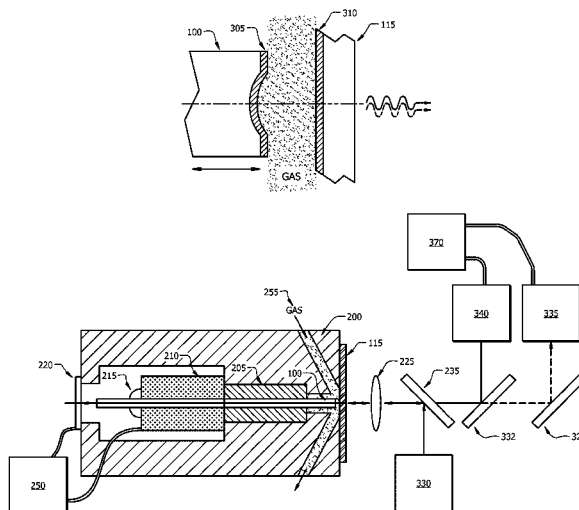

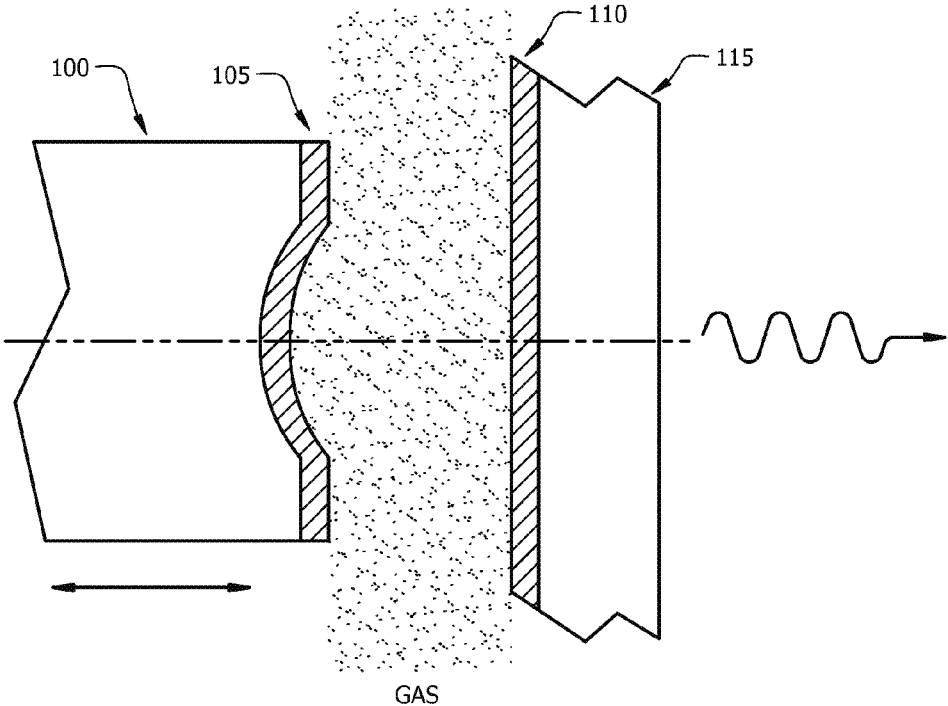

FIG. 1

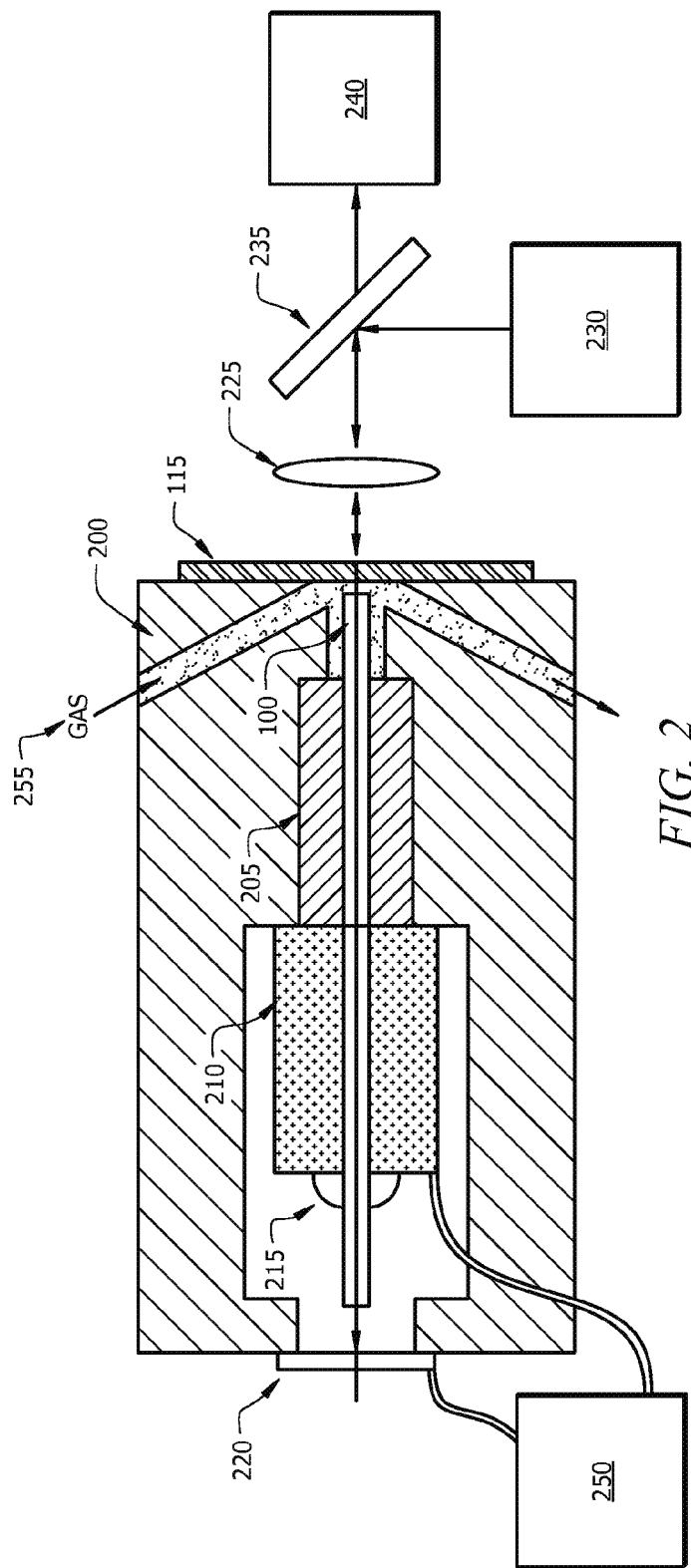
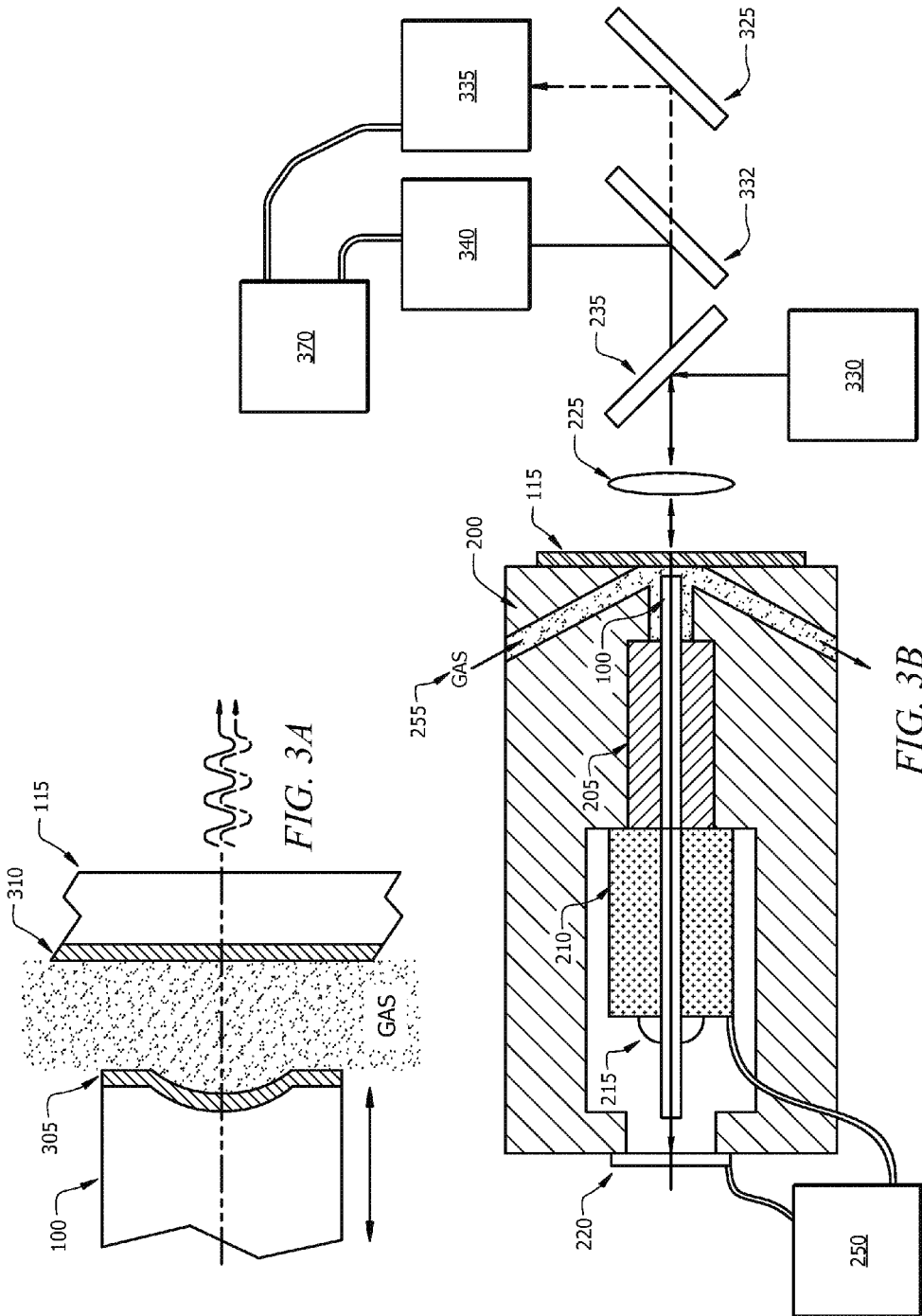

FIG. 2



DUAL-GAS MICROCAVITY RAMAN SENSOR AND METHOD OF USE

CROSS-REFERENCE TO RELATED APPLICATIONS

The present invention claims priority to co-pending U.S. Non-Provisional patent application Ser. No. 13/542,282, filed on Jul. 5, 2012 and entitled "Microcavity Raman Sensor and Method of Use", which claims priority to U.S. Provisional Patent Application No. 61/505,270, filed on Jul. 7, 2011 and entitled "Microcavity Raman Sensor and Method of Use".

BACKGROUND OF THE INVENTION

When a Raman active medium is placed in an optical cavity, a large enhancement in the scattering efficiency can be realized. The enhancement can be observed when the cavity is made resonant with either the wavelength of the excitation light or the wavelength of the Raman scattered light. The effect is maximized when the cavity is made simultaneously resonant with both, i.e., when a double resonance is obtained. The exact magnitude of the enhancement depends on, among other factors, the finesse of the cavity at the two wavelengths and the volume of the mode sustained by the microcavity.

In the prior art the double resonance condition could be achieved only for a very thin solid sample with a thickness of less than one wavelength. The sample was made to have plane parallel surfaces, effectively creating a planar resonator with two flat partial reflectors forming the cavity. Because of the fixed spacing of the cavity, resonance with the wavelength of the excitation light could be established only for an off-axis laser beam. As a result, the resonance was accompanied by a high walk-off loss. Furthermore, planar resonators are inherently only quasi-stable, and are therefore precluded from having a high finesse even for axial beams because of diffraction. In addition, the extension of this approach to fluid samples is not described in the prior art.

Accordingly, what is needed in the art is a microcavity arrangement capable of sustaining the double resonance condition with high finesse for Raman scattering in fluids, thereby providing for the measurement of the concentration of one or more species of interests in a fluid sample.

SUMMARY OF THE INVENTION

In accordance with the present invention is provided a novel Raman sensor based on quantum electrodynamic effects capable of detecting trace amounts of chemicals in gases and liquids with a high degree of accuracy.

In accordance with the present invention, an ultra-sensitive chemical sensor is provided that is based on an enhanced spontaneous Raman emission as a result of cavity quantum electrodynamic effects. More specifically, the sensor in accordance with the present invention makes use of a double resonance of a stable Fabry-Perot microcavity with both the excitation laser frequency and the Raman frequency. As such, the Raman shift corresponds to an integer times the free spectral range of the microcavity. Because the Raman frequency directly depends on the excitation laser's frequency, the fulfillment of the resonance condition for the excitation laser frequency guarantees that resonance with the Raman frequency is also satisfied.

In a particular embodiment, a Raman sensor for detecting the concentration of a single species of interest in a sample may include a first substantially flat reflector and an adjustable optical fiber, wherein the adjustable optical fiber is trans-

latable in a direction parallel to the fiber optic axis of the optical fiber, and a second substantially concave reflector positioned at a proximate end of the optical fiber and aligned substantially parallel to the first reflector, the second reflector separated from the first reflector by a distance to form a microcavity having a microcavity length equal to the distance between the first reflector and the second reflector, wherein the microcavity length is dependent upon the Raman transition of a species of interest to be detected. The sensor may further include an excitation laser positioned to emit an excitation wavelength incident upon the first reflector and the second reflector, wherein the wavelength of the excitation laser is dependent upon the microcavity length between the first reflector and the second reflector and a Raman emission signal detector positioned to receive the Raman emission coupled out of the first reflector and to detect the concentration of the species of interest within a sample positioned between the first reflector and the second reflector.

In operation of the single-gas sensor, a sample containing a species of interest is introduced into a microcavity having a microcavity length dependent upon the Raman emission of the species of interest. An excitation laser signal having a wavelength determined by the microcavity length is then introduced into the microcavity. The Raman emission of the sample is then measured to determine the concentration of the species of interest within the sample.

In an additional embodiment, a dual-gas Raman sensor for detecting the concentration of a first species of interest and a second species of interest in a sample is provided. In this embodiment, the dual-gas sensor includes a first reflector that exhibits a high reflectivity near the Raman shifted emission for the first species of interest and a moderate reflectivity near the Raman shifted emission for the second species of interest and a second reflector that exhibits a high reflectivity near the Raman shifted emission for the first species of interest and a moderate reflectivity near the Raman shifted emission for the second species of interest. The second reflector is positioned at a proximate end of an optical fiber and aligned substantially parallel to the first reflector. The second reflector is separated from the first reflector by a distance to form a microcavity having a microcavity length equal to the distance between the first reflector and the second reflector, wherein the microcavity length is dependent upon the Raman transition of the first species of interest to be detected. An excitation laser positioned to emit at an excitation wavelength incident upon the first reflector and the second reflector is used to provide the excitation source for the microcavity. The wavelength of the excitation laser is dependent upon the microcavity length between the first reflector and the second reflector. To measure the relative density of the two species in the sample, a first Raman emission signal detector positioned to receive the Raman emission coupled out of the first reflector and to detect the concentration of the first species of interest within a sample positioned between the first reflector and the second reflector and a second Raman emission signal detector positioned to receive the Raman emission coupled out of the first reflector and to detect the concentration of the second species of interest within a sample positioned between the first reflector and the second reflector.

In operation of the dual-gas sensor, a sample containing a first species of interest and a second species of interest is introduced into a microcavity having a microcavity length dependent upon the Raman emission of the first species of interest. An excitation laser signal having a wavelength determined by the microcavity length is then introduced into the microcavity. A first Raman emission of the sample is measured to determine the concentration of the first species of

3

interest in the sample and a second Raman emission of the sample is simultaneously measured to determine the concentration of the second species of interest in the sample.

To couple the laser beam into the microcavity, the present invention may include a dichroic filter positioned between the excitation laser and the first reflector, the dichroic filter having high reflectance at the wavelength of the excitation laser and high transmittance at the Raman emission wavelength.

To mode match the laser beam into the microcavity and to collimate the Raman emission coupled out of the first reflector onto the Raman emission signal detector, the present invention may include a lens positioned between the first reflector and the dichroic filter.

In a particular embodiment, the optical fiber may further be positioned within a close fitting ferrule to constrain the optical fiber and to allow translation of the optical fiber in the direction parallel to the fiber's optic axis.

The present invention may further include an excitation light detector positioned at a distance from the distal end of the optical fiber to detect the transmitted laser power and a piezoelectric transducer coupled to a distal end of the optical fiber to adjust the length of the microcavity by translating the optical fiber in the direction parallel to the fiber's optic axis dependent upon the detected excitation laser power.

The invention accordingly comprises the features of construction, combination of elements, and arrangement of parts that will be exemplified in the disclosure set forth hereinafter and the scope of the invention will be indicated in the claims.

BRIEF DESCRIPTION OF THE DRAWINGS

For a fuller understanding of the nature and objects of the invention, reference should be made to the following detailed disclosure, taken in connection with the accompanying drawings, in which:

FIG. 1 illustrates the single-gas doubly resonant Fabry-Perot microcavity in accordance with an embodiment of the present invention.

FIG. 2 is a schematic diagram illustrating the single-gas doubly resonant microcavity Raman sensor in accordance with an embodiment of the present invention.

FIG. 3A illustrates the dual-gas doubly resonant microcavity Fabry-Perot microcavity in accordance with an embodiment of the present invention

FIG. 3B is a schematic diagram illustrating the dual-gas doubly resonant microcavity Raman sensor in accordance with an embodiment of the present invention.

DETAILED DESCRIPTION OF THE INVENTION

The ability of a cavity-resonant electric field to influence the spontaneous emission rate of an atomic transition is well known. In the case of Raman scattering, the rate of Raman photons spontaneously emitted into the cavity mode per molecule can be written as:

$$A_c = \frac{c^3 v_L \phi}{3v_R^3 V(\Delta v_C + \Delta v_R)} \frac{d\sigma}{d\Omega} \quad (1)$$

where v_L and v_R are the frequencies of the laser and Raman photons, ϕ is the laser photon flux density, V the cavity mode volume at the Raman wavelength, Δv_C the cavity linewidth at the Raman wavelength, Δv_R the Raman transition linewidth, and $d\sigma/d\Omega$ the differential Raman scattering cross section. If there are n_V molecules responsible for the Raman scattering in

4

the mode volume, then the total rate of emission into the cavity mode can be found from:

$$n_V A_c = \frac{c^3 N L P}{3hVv_R^3(\Delta v_C + \Delta v_R)} \frac{d\sigma}{d\Omega} \quad (2)$$

where N is the density of molecules of interest, L is the cavity length, P is the intracavity laser power, and h is Planck's constant. The differential scattering cross section itself varies as the fourth power of the Raman shifted frequency, making the net emission rate into the cavity mode vary approximately as the square of v_R for a fixed pump photon flux density.

Thus, the result given in Eq. (2), along with the laws governing the scaling of Gaussian modes with changes in the resonator's dimensions, shows that for a given excitation laser power, Raman emission into the cavity mode is increased as the resonator mode volume is decreased.

For fundamental Gaussian modes, the double resonance condition requires that:

$$\frac{mc}{2nL} - \frac{m'c}{2nL} = \Delta v_V \quad (3)$$

where Δv_V is the Raman frequency, m and m' are integers and n is the refractive index of the sample (the same refractive index is assumed for both the laser and Raman shifted wavelengths, because they are generally very close to each other).

When the frequencies are expressed in terms of wavenumbers, Equation (3) may be written as:

$$\frac{\Delta m}{2nL} = \Delta v_V \quad (4)$$

Thus it is seen that only a discrete set of cavity lengths are permitted for any given Raman transition. These cavity lengths in turn dictate a discrete set of permissible excitation laser wavelengths.

With reference to FIG. 1, in one embodiment the microcavity is comprised of a concave reflector **105** fabricated at the end of an optical fiber **100** and a flat (or slightly concave) reflector **110** deposited on a thin substrate **115**. The concave reflector **105** conforms to a spherically shaped crater formed in a polished end of the optical fiber **100**. This micro-indentation feature can be created, for example, by the process of ablation with the use of one or more pulses of a focused beam from a CO₂ laser. The reflectors **105** and **110** can be produced, for example, by ion beam sputtering, which is known to be capable of yielding coatings with extremely high reflectivities. The sample from which Raman emission is sought is made to fill the space between mirrors **105** and **110**. For maximum enhancement of the Raman emission from the sample, the reflectivities of the mirrors should be made as large as possible at both the wavelength of the excitation laser and the wavelength of the Raman emission.

In a preferred embodiment, the reflector **110** is kept in a fixed position while the reflector **105** is constrained to be translatable only in the direction parallel to the fiber **100** axis. The excitation laser beam is made incident into the microcavity from the right in FIG. 1. Raman emission from the sample is coupled out of the microcavity through the reflector **110**.

A schematic illustrating the overall Raman sensor is shown with reference to FIG. 2. Output from a stabilized laser **230**,

tuned to the appropriate excitation wavelength, is made incident on a dichroic reflector **235**, which is highly reflective at the excitation wavelength and highly transmitting at the Raman emission wavelength. The laser light from the stabilized laser **230** is then mode matched into the microcavity **200** with the use of lens **225**. The optical fiber **100** is inserted into a close fitting ferrule **205** which permits free translation in the direction parallel to the fiber's optic axis. At the other end of the ferrule **205** the fiber **100** is attached to a piezoelectric transducer **210** with the use of adhesive **215**. The laser light exiting the fiber is made incident on detector **220**. The output from the detector **220** is used to keep the microcavity **200** always resonant with the excitation laser wavelength through the use of feedback electronics **250**. The piezoelectric transducer **210** may adjust the cavity length (i.e. separation between the reflectors **105**, **110** of FIG. 1) as necessary for initial set-up as well as during subsequent operation of the sensor to compensate for any dimensional changes due to temperature variations. The Raman emission coupled out of the flat reflector **110** positioned on the substrate **115** of the microcavity is collimated by lens **225**, passed through the dichroic filter **235**, and made incident on detector **240**. Once the system has been calibrated, the Raman signal measured by detector **240** will directly provide the concentration of the species of interest from the sample **255** introduced into the microcavity **200**, which produces the Raman emission.

In an exemplary embodiment, the capability of the doubly resonant microcavity Raman sensor will now be illustrated in the context of its application to the measurement of atmospheric CO₂ concentration. Suppose the 1,388 cm⁻¹ Raman transition in CO₂ is to be employed and the microcavity is semi-confocal. Then one possible cavity length is 25 μm (for Δm=7), and one possible excitation laser wavelength is 640 nm (for m=78), with a corresponding Raman emission wavelength of 702 nm. The differential Raman cross section for the 1,388 cm⁻¹ transition for 640 nm excitation is approximately 2(10)⁻³¹ cm²/sr.

Suppose further that a laser power of 100 mW is available and that the microcavity mirrors (**105**, **110**) have a reflectivity of 99.99% at both 640 nm and 702 nm. At a typical atmospheric CO₂ concentration of 400 ppm and for an expected Raman linewidth of around 0.2 GHz, one calculates a Raman emission rate through mirror **110** of 5(10)⁶ photons/s with the use of Eq. (2). If the detector **240** is a single photon counter and a measurement time of 1 second is employed, then a shot noise of approximately 2(10)³ counts can be expected. This implies that changes in the CO₂ concentration of about 0.2 ppm (i.e. 0.05% relative change) should be detectable with a response time of 1 second.

In an additional embodiment, the microcavity sensor may be modified to simultaneously measure emission from two Raman transitions, thereby providing a dual-gas microcavity sensor that is capable of simultaneously measuring the concentration of two different gases or liquids in a given sample.

In the dual-gas microcavity sensor, when measuring the concentration of a first species and a second species within a given sample, if the reflectivity of the micromirrors of the microcavity at the Raman shifted wavelength of the second species is relatively low, significant enhancement is still possible even when the microcavity is not exactly resonant with the wavelength of the second species. This realization makes possible the simultaneous measurement of the density of a first (trace) species relative to that of a second (majority) atmospheric gas, such as N₂ or O₂.

Neglecting phase changes at the mirrors of the microcavity and assuming unit refractive index for air, the double resonance condition is given by:

$$\frac{\Delta m}{2L} = \Delta \bar{\nu}_v \quad (5)$$

where Δm is an integer, L is the microcavity length, and Δ $\bar{\nu}_v$ represents the Raman shift. The sharpness of the double resonance is given by the width of the tuning curve:

$$\delta \bar{\nu} = (\bar{\nu} / \Delta \bar{\nu}_R) (\Delta \bar{\nu}_R + \Delta \bar{\nu}_C) \quad (6)$$

where $\bar{\nu}$ is the laser frequency at the peak of the double resonance, Δ $\bar{\nu}_R$ is the Raman linewidth (typically 0.1 cm⁻¹ at 1 atm.), and Δ $\bar{\nu}_C$ is the cavity linewidth (<< Δ $\bar{\nu}_R$ for mirror reflectivities higher than 99.9%). Therefore, for a typical laser frequency of 10,000 cm⁻¹, the width of the tuning curve is δ $\bar{\nu}$ ~ 1 cm⁻¹. Thus, the chances of satisfying the double resonance condition for two arbitrary Raman transitions (i.e. a first species and a second species) is on the order of 1 in 1,000. Adjusting to account for the non-unity values of the refractive index of air and the phase shifts at the mirrors does not materially alter this estimate.

In the present invention, instead of attempting to realize two strong double resonances with high micromirror reflectivity at both Raman shifted wavelengths, a microcavity sensor is implemented in which the reflectivity at the second Raman shifted wavelength is low. For example, assume that the reflectivity at the second Raman shifted wavelength is only 30%. Then, for a typical microcavity length of L=30 μm, Δ $\bar{\nu}_C$ ~ 20 cm⁻¹ and δ $\bar{\nu}$ ~ 200 cm⁻¹. The calculated value is larger than the free spectral range of the microcavity. Hence, the Raman shifted wavelength for the second species is always going to be near the peak of a microcavity mode in the case of a weak double resonance. Nevertheless, significant enhancement for the Raman emission from the second species can still be realized.

In an exemplary embodiment, the first species of interest to be detected is CO₂ with a Raman shift of 1,388 cm⁻¹ and the second species of interest to be detected is N₂ with a Raman shift of 2,329 cm⁻¹. The Raman photon emission rate into the microcavity mode for a confocal resonator relative to that in free space into the same solid angle at the peak of the double resonance can be written as:

$$\rho = (12\lambda_R) / [\pi^2 L (\lambda_L + \lambda_R) (\Delta \bar{\nu}_R + \Delta \bar{\nu}_C)] \quad (7)$$

where λ_L and λ_R are the laser and Raman shifted wavelengths, respectively. For λ_L=515 nm and λ_R=585 nm (as appropriate for N₂), L=30 μm, Δ $\bar{\nu}_R$ =0.1 cm⁻¹ and Δ $\bar{\nu}_C$ =20 cm⁻¹, the enhancement in the Raman photon emission rate is ρ=11.

In order to satisfy the strong double resonance for CO₂ with λ_L=515 nm, it can be seen from Equation 5 that the cavity length needs to be 28.8 μm for Δm=8. For the same cavity length, the weak double resonance for N₂ would be detuned by 72 cm⁻¹ with Δm=13. But, since the width of the tuning curve is ~200 cm⁻¹, an approximately ten-fold enhancement can still be expected over the case where the microcavity is only slightly resonant with the excitation laser wavelength. Since N₂ is more than 10³ times more abundant than CO₂ in air, the two Raman emission signals are of comparable magnitude.

With reference to FIGS. 3A and 3B, a dual-gas Raman sensor in accordance with the present invention for detecting the concentration of a first species of interest in a sample and a second species of interest in a sample is illustrated. The dual-gas sensor includes a first reflector **310** that exhibits a

high reflectivity near the Raman shifted emission for the first species of interest and a moderate reflectivity near the Raman shifted emission for the second species of interest and a second reflector **305** that exhibits a high reflectivity near the Raman shifted emission for the first species of interest and a moderate reflectivity near the Raman shifted emission for the second species of interest. The second reflector **305** is fabricated at the tip on an optical fiber (**100** of FIG. **1**) and aligned substantially parallel to the first reflector **310**. The second reflector **305** is separated from the first reflector **310** by a distance to form a microcavity having a microcavity length equal to the distance between the first reflector **310** and the second reflector **305**, wherein the microcavity length is dependent upon the Raman transition frequency of the first species of interest to be detected. An excitation laser **330** is positioned to emit at an excitation wavelength incident upon the first reflector **310** and the second reflector **305**, wherein the wavelength of the excitation laser **330** is dependent upon the microcavity length between the first reflector **310** and the second reflector **305**. A first Raman emission signal detector **340** is positioned to receive the Raman emission coupled out of the first reflector **310** and to detect the concentration of the first species of interest within a sample positioned between the first reflector **310** and the second reflector **305**. A second Raman emission signal detector **335** is positioned to receive the Raman emission coupled out of the first reflector **310** and to detect the concentration of the second species of interest within a sample positioned between the first reflector **310** and the second reflector **305**.

In a particular embodiment, the first reflector **310** may be fabricated on a substantially planar substrate and the second reflector **305** may conform to a spherically shaped depression formed within a polished end of the optical fiber. In an exemplary embodiment, the radius of curvature of the first reflector **310** may be approximately planar and the radius of curvature of the second mirror **305** may be approximately 50 μm .

After the initial alignment has been performed, the distance (L) between the first reflector **310** and the second reflector **305**, and as such the length of the microcavity, is controlled by a piezoelectric transducer **210** coupled to the second reflector **305**. The length of the microcavity is controlled by feedback electronics **250** to guarantee that the tunable laser **330** is always on resonance. In a particular embodiment, the laser **330** is mode-matched to the microcavity **200** using a single aspheric lens **225** and the laser **330** is maintained on resonance with the cavity **200** at all times using a Pound-Drever-Hall locking scheme.

To detect the concentration of the first species of interest, a first filter **332** is positioned between the first reflector **310** and the first Raman emission signal detector **340**, wherein the first filter **332** has a high reflectance at the wavelength of the Raman emission of the first species of interest and a high transmittance at the Raman emission wavelength of the second species of interest.

To detect the concentration of the second species of interest, a second filter **325** is positioned between the first reflector **310** and the second Raman emission signal detector **335**, wherein the second filter **325** has a high reflectance at the wavelength of the Raman emission of the second species of interest and a high transmittance for all other wavelengths.

The output from the first Raman emission signal detector **340** and from the second Raman emission detector **335** may be further processed to provide an output signal **370** from the dual-gas sensor.

In operation, the dual-gas sensor detects the concentration of a first species of interest and a second species of interest within a sample using Raman emission by introducing a

sample into a microcavity, wherein the microcavity is formed by a first reflector that exhibits a high reflectivity near the Raman shifted emission for the first species of interest and a moderate reflectivity near the Raman shifted emission for the second species of interest and a second reflector that exhibits a high reflectivity near the Raman shifted emission for the first species of interest and a moderate reflectivity near the Raman shifted emission for the second species of interest. The second reflector is positioned at a proximate end of an optical fiber and aligned substantially parallel to the first reflector and the second reflector is separated from the first reflector by a distance to form a microcavity having a microcavity length equal to the distance between the first reflector and the second reflector, wherein the microcavity length is dependent upon the Raman transition of the first species of interest to be detected. An excitation laser beam is introduced into the microcavity to establish a double resonance condition within the microcavity, wherein an excitation wavelength of the excitation laser beam is dependent upon the microcavity length between the first reflector and the second reflector. A first Raman emission signal coupled out of the first reflector is detected to determine the concentration of the first species of interest within the sample and a second Raman emission signal coupled out of the first reflector is detected to determine the concentration of the second species of interest within the sample.

In an exemplary embodiment, the air sample to be measured is delivered directly to the hermetically sealed microcavity **200**. Although applicable to a wide variety of gases, this exemplary embodiment illustrates the working principle of the dual-gas sensor for the specific case of CO_2 as the minority gas and N_2 as the majority gas. Assume that a single frequency laser **330** with $\lambda_L=515$ nm is available, which is continuously frequency tunable via an electrical input as previously described.

In the exemplary embodiment, the reflectors **305** and **310** are dielectrically coated in such a manner that the reflectivity is high (>99.99%) near both the laser frequency $\lambda_L=515$ nm and the Raman shifted emission for CO_2 ($\lambda_R=555$ nm) and moderate (~50%) for the Raman shifted emission from N_2 ($\lambda_R=585$ nm). In one embodiment, commercial multilayer dielectric coating processes commonly known in the art can be used to dielectrically coat the reflectors **305** and **310** to exhibit the desired reflectivity. Arranged in reflection from the cavity are filters **332** and **325** that select the Raman emission from each species. Single photon detectors **340** and **335** are then used to record the Raman emission signals from each of the filters to measure the concentration of both the first species of interest and the second species of interest.

It can be shown that the ratio of the Raman scattered signals from CO_2 and N_2 is particularly robust to fluctuations in laser intensity and/or wavelength, thus ensuring precise determination of the relative density of CO_2 and N_2 in the air sample.

It will thus be seen that the objects set forth above, and those made apparent from the foregoing disclosure, are efficiently attained and since certain changes may be made in the above construction without departing from the scope of the invention, it is intended that all matters contained in the foregoing disclosure or shown in the accompanying drawings shall be interpreted as illustrative and not in a limiting sense.

It is also to be understood that the following claims are intended to cover all of the generic and specific features of the invention herein described, and all statements of the scope of the invention that, as a matter of language, might be said to fall therebetween.

What is claimed is:

1. A Raman sensor for detecting the concentration of a first species of interest and a second species of interest in a sample, the sensor comprising:

a first reflector that exhibits a high reflectivity near the Raman shifted emission for the first species of interest and a moderate reflectivity near the Raman shifted emission for the second species of interest;

a second reflector that exhibits a high reflectivity near the Raman shifted emission for the first species of interest and a moderate reflectivity near the Raman shifted emission for the second species of interest, positioned at a proximate end of an optical fiber and aligned substantially parallel to the first reflector, the second reflector separated from the first reflector by a distance to form a microcavity having a microcavity length equal to the distance between the first reflector and the second reflector, wherein the microcavity length is dependent upon the Raman transition of the first species of interest to be detected;

an excitation laser positioned to emit at an excitation wavelength incident upon the first reflector and the second reflector, wherein the wavelength of the excitation laser is dependent upon the microcavity length between the first reflector and the second reflector;

a first Raman emission signal detector positioned to receive the Raman emission coupled out of the first reflector and to detect the concentration of the first species of interest within a sample positioned between the first reflector and the second reflector; and

a second Raman emission signal detector positioned to receive the Raman emission coupled out of the first reflector and to detect the concentration of the second species of interest within a sample positioned between the first reflector and the second reflector.

2. The sensor of claim 1, wherein the microcavity is a Fabry-Perot microcavity.

3. The sensor of claim 1, wherein optical fiber is an adjustable optical fiber, wherein the adjustable optical fiber is translatable in a direction parallel to the fiber optic axis of the optical fiber.

4. The sensor of claim 1, wherein the first reflector is fabricated on a substantially planar substrate.

5. The sensor of claim 1, wherein the second reflector conforms to a spherically shaped depression formed within a polished end of the optical fiber.

6. The sensor of claim 1, wherein the first reflector is substantially curved.

7. The sensor of claim 1, wherein the second reflector is substantially curved.

8. The sensor of claim 1, further comprising a piezoelectric transducer coupled to the second reflector, the piezoelectric transducer to adjust the length of the microcavity by translating the optical fiber in the direction parallel to the fiber's optic axis.

9. The sensor of claim 8, further comprising:

an excitation light detector positioned at a distance from the distal end of the optical fiber,

a feedback module coupled to the excitation light detector and to the piezoelectric transducer, the excitation light detector to receive emissions from the distal end of the optical fiber and to adjust the length of the microcavity through the feedback module.

10. The sensor of claim 1, further comprising a first filter positioned between the first reflector and the first Raman emission signal detector, the first filter having high reflectance at the wavelength of the Raman emission of the first

species of interest and a high transmittance at the Raman emission wavelength of the second species of interest.

11. The sensor of claim 1, further comprising a second filter positioned between the first reflector and the second Raman emission signal detector, the second filter having high reflectance at the wavelength of the Raman emission of the second species of interest and a high transmittance at all other wavelengths.

12. The sensor of claim 1, further comprising a lens positioned between the first reflector and the excitation laser, the lens to mode match the laser beam from the excitation laser into the microcavity.

13. The sensor of claim 1, wherein the sample is selected from the group consisting of a gas and a liquid.

14. The sensor of claim 1, wherein the first Raman emission signal detector is a single photon counter.

15. The sensor of claim 1, wherein the second Raman emission signal detector is a single photon counter.

16. A Raman sensor for detecting the concentration of a first species of interest and a second species of interest in a sample, the sensor comprising:

a first reflector that exhibits a high reflectivity near the Raman shifted emission for the first species of interest and a moderate reflectivity near the Raman shifted emission for the second species of interest;

a second reflector that exhibits a high reflectivity near the Raman shifted emission for the first species of interest and a moderate reflectivity near the Raman shifted emission for the second species of interest, positioned at a proximate end of an optical fiber and aligned substantially parallel to the first reflector, the second reflector separated from the first reflector by a distance to form a microcavity having a microcavity length equal to the distance between the first reflector and the second reflector, wherein the microcavity length is dependent upon the Raman transition of the first species of interest to be detected;

an excitation laser positioned to emit at an excitation wavelength incident upon the first reflector and the second reflector, wherein the wavelength of the excitation laser is dependent upon the microcavity length between the first reflector and the second reflector;

a piezoelectric transducer coupled to the first reflector and to the second reflector, the piezoelectric transducer to adjust the length of the microcavity by translating the optical fiber in the direction parallel to the fiber's optic axis;

an excitation light detector positioned at a distance from the distal end of the optical fiber;

a feedback module coupled to the excitation light detector and to the piezoelectric transducer, the excitation light detector to receive emissions from the distal end of the optical fiber and to adjust the length of the microcavity through the feedback module;

a first Raman emission signal detector positioned to receive the Raman emission coupled out of the first reflector and to detect the concentration of the first species of interest within a sample positioned between the first reflector and the second reflector;

a first filter positioned between the first reflector and the first Raman emission signal detector, the first filter having high reflectance at the wavelength of the Raman emission of the first species of interest and a high transmittance at the Raman emission wavelength of the second species of interest;

a second Raman emission signal detector positioned to receive the Raman emission coupled out of the first

11

reflector and to detect the concentration of the second species of interest within a sample positioned between the first reflector and the second reflector; and a second filter positioned between the first reflector and the second Raman emission signal detector, the second filter having high reflectance at the wavelength of the Raman emission of the second species of interest and a high transmittance at all other wavelengths.

17. A method for detecting the concentration of a first species of interest and a second species of interest within a sample using Raman emission, the method comprising:

introducing a sample into a microcavity, the microcavity formed by a first reflector that exhibits a high reflectivity near the Raman shifted emission wavelength for the first species of interest and a moderate reflectivity near the Raman shifted emission wavelength for the second species of interest and a second reflector that exhibits a high reflectivity near the Raman shifted emission wavelength for the first species of interest and a moderate reflectivity near the Raman shifted emission wavelength for the second species of interest, positioned at a proximate end of an optical fiber and aligned substantially parallel to the first reflector, the second reflector separated from the first reflector by a distance to form a microcavity having a microcavity length equal to the distance between the first reflector and the second reflector, wherein the microcavity length is dependent upon the Raman transition of the first species of interest to be detected;

12

introducing an excitation laser beam into the microcavity to establish a double resonance condition within the microcavity, wherein an excitation wavelength of the excitation laser beam is dependent upon the microcavity length between the first reflector and the second reflector; and

detecting a first Raman emission signal coupled out of the first reflector to determine the concentration of the first species of interest within the sample; and

detecting a second Raman emission signal coupled out of the first reflector to determine the concentration of the second species of interest within the sample.

18. The method of claim **17**, further comprising adjusting the microcavity length to establish a double resonance in the microcavity for the excitation laser as well as the Raman transition in the first species of interest.

19. The method of claim **17**, wherein detecting a first Raman emission signal coupled out of the first reflector to determine the concentration of the first species of interest within the sample further comprising filtering the Raman emission signal to reflect substantially at the Raman emission wavelength of the first species of interest.

20. The method of claim **17**, wherein detecting a second Raman emission signal coupled out of the first reflector to determine the concentration of the second species of interest within the sample further comprising filtering the Raman emission signal to reflect substantially at the Raman emission wavelength of the second species of interest.

* * * * *